



# Installation Instructions

Detector Models W-1250 and 125-W

## Installation and Operating Instructions for Portable Large Meter Testers

### DETECTOR MODEL W-1250

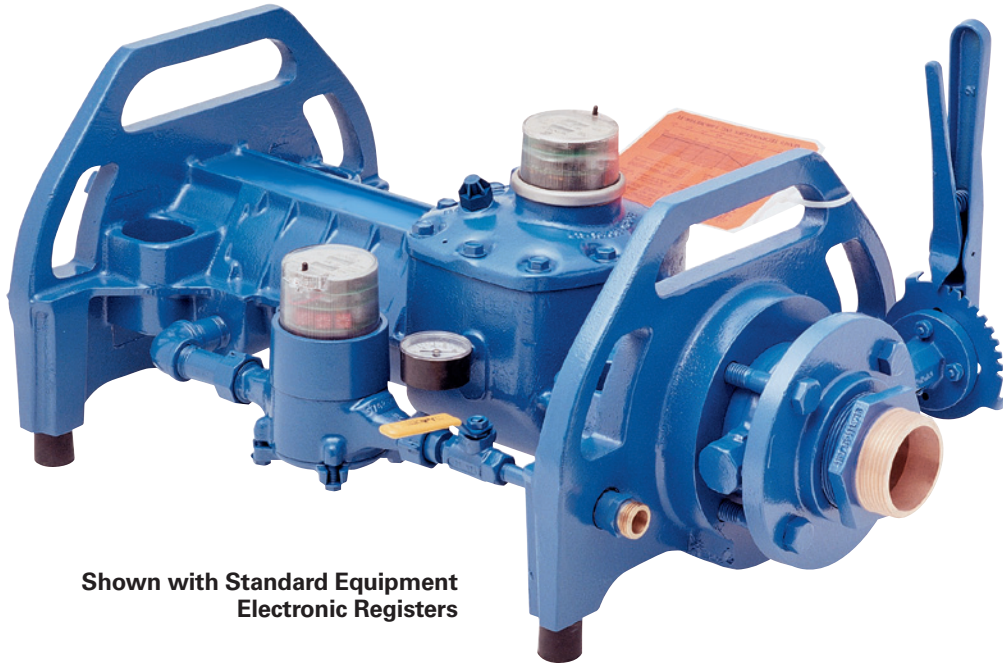

Shown with Standard Equipment  
Electronic Registers

### DETECTOR MODEL 125-W

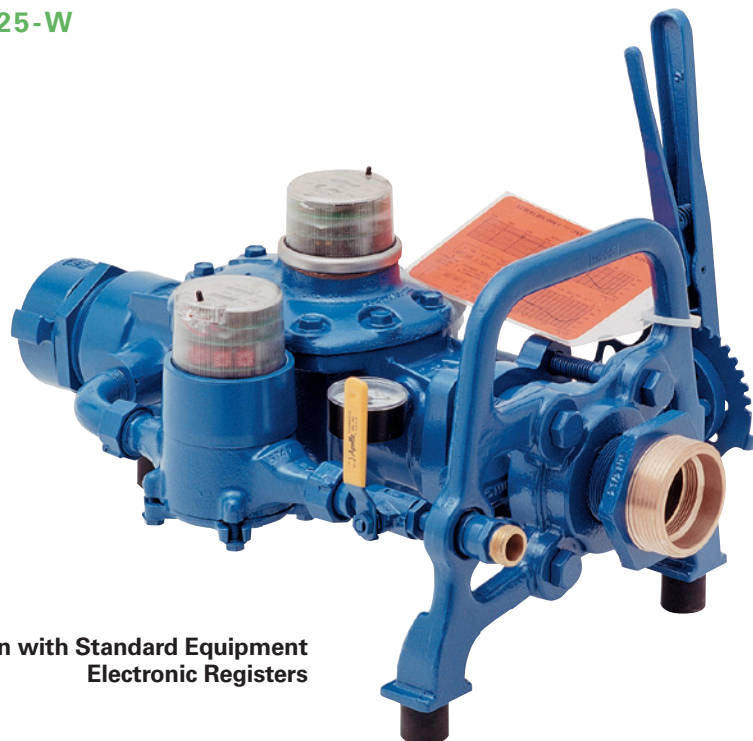

Shown with Standard Equipment  
Electronic Registers

## DETECTOR MODEL W-1250

The Sensus W-1250 portable large meter tester includes everything needed for accuracy field testing water meters 1-1/2" and larger. The tester assembly includes a 5/8" SR II® meter for measuring low flows and a W-1250 Turbo Meter for measuring high flows. Flow rates from 1/4 to 1250 gallons a minute are easily controlled by two positive opening valves. A pressure gauge is included to measure line pressure. Fire hose, thread adapters and fittings are also part of the package. Weighing only 80 pounds, the tester is easily portable.

### Contents

- 1 5/8" SR II meter for measuring low flows
- 2 4" model W-1250 Turbo Meter for measuring high flows
- 3 Pressure gauge for measuring line pressure
- 4 Shut-off and flow rate control valves
- 5 25 foot reinforced fire hose. Downstream outlet hose optional
- 6 Certified accuracy test curve
- 7 Spanner wrench for fire hose couplings
- 8 Register test rings (2)
- 9 Adaptor – fire hose to pipe threads
- 10 Pipe nipples with bushings (1", 1-1/2" and 2" sizes)

**Note:** Standard equipment resettable electronic registers are available in gallons, cubic feet and liters, with gpm as standard rate.



## DETECTOR MODEL 125-W



### Contents

- 1 5/8" SR II meter for measuring low flows
- 2 3" model 125-W fire hydrant meter for measuring high flows
- 3 Pressure gauge for measuring line pressure
- 4 Shut-off and flow rate control valves
- 5 25 foot reinforced fire hose. Downstream outlet hose optional
- 6 Certified accuracy test curve
- 7 Spanner wrench for fire hose couplings
- 8 Register test rings (2)
- 9 Adaptor – fire hose to pipe threads
- 10 Pipe nipples with bushings (1", 1-1/2" and 2" sizes)

**Note:** Standard equipment resettable electronic registers are available in gallons, cubic feet and liters, with gpm as standard rate.

### Optional Accessory Kit

The Sensus 125-W portable large meter tester contains everything needed for field testing water meters 1-1/2" – 8" in size. The tester consists of a 5/8" SR II meter for measuring low flows, and a Turbo Meter that measures high flows. Flow rates from 1/4 to 300 gallons per minute are easily controlled by two positive opening indicator valves. A pressure gauge is included for measuring line pressure. An accessory kit containing fire hoses, thread adapters and fittings are available as an option. Weighing only 45 pounds, the tester can be easily operated by one person.

**Note:** All large water meters should be tested periodically to insure proper operation and accurate registration. A test plug connection should always be provided to allow on-site accuracy testing without removing the meter from the line. Since a typical large meter's performance can be determined when the lowest 15% of the flow range is tested, the W-1250 tester can check most meters up through 16" size and the 125-W tester can check most meters up through 8" size. They can also be used for shop testing when suitable test equipment is not available.

## INSTALLATION

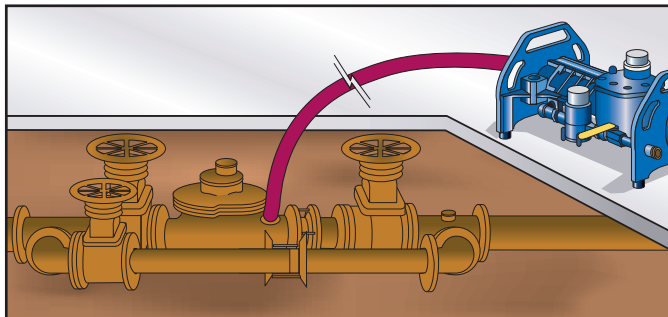

Detector Model W-1250

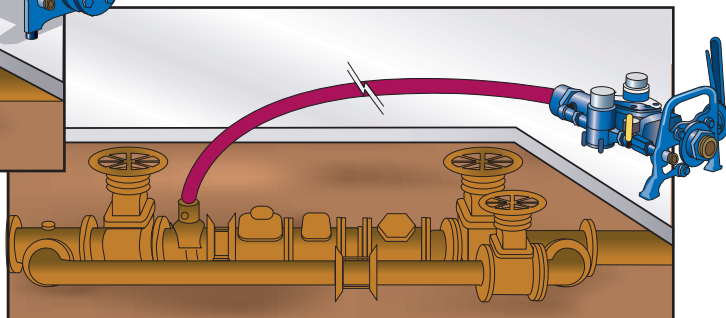

Detector Model 125-W

Bypass piping is recommended for providing service to the customer during testing. The tester should be connected to a test outlet (either on the meter or two or more pipe diameters downstream) with a section of fire hose.

### Operating Instructions

- 1 Close both the upstream (inlet) and downstream (outlet) shutoff valves, to isolate the meter to be tested. Attach required fire hose(s) from the meter test outlet to the upstream inlet connection of the tester. Be sure to maintain a straight fire hose. Use 25' fire hose, minimum length.

**CAUTION:** Bending of fire hose(s) may cause the tester to become unstable under pressure.

- 2 Close the small valve on the tester. Open the large butterfly valve on the tester and position it in notch #4 on the indicator flange. **Slowly** open the valve upstream of the meter to be tested, purging all air from the line and tester. Continue to **slowly** open the upstream valve until the valve is in the fully open position. Always keep a firm grip on the tester during operation.

- 3 Slowly open the tester's small valve, **and then** the tester's main butterfly valve. Be particularly careful ... **if you detect that the tester is not firmly stable on the ground, take measures to anchor the tester!** Check to see that the hose fittings are watertight and maintain a high flow velocity until all the air has been purged from the entire set-up. Close the tester's small valve **and then slowly** close the main valve. Watch carefully for excessive pressure "spikes" on the pressure gauge. Make sure that as you slowly shut-off the valve you don't cause a water hammer that exceeds a 150 p.s.i. reading on the pressure gauge.

**CAUTION:** Never "slam" the main valve shut while flow testing. Severe water hammer will follow and may cause damage to the main utility system. The system is now ready to begin testing.

**NOTE:** For the W-1250 on flow rates of 15 GPM and less, use the small SR II meter. For flow rates above 15 GPM, use the main (turbo) meter; which has a maximum flow rate of 1250 GPM.

**NOTE:** For the 125-W on flow rates of 15 GPM and less, use the by-pass SR II meter. For flow rates above 15 GPM, use the main (fire hydrant) meter; its maximum flow rate is 300 GPM. (When most meters lose their accuracy, they do so

at the low end of their flow range. Performance can usually be determined by accuracy testing the lower 15% of the meter's flow capacity.)

- 4 Run water through the tester's main valve until the register sweep hand on the meter to be tested is at some convenient indication (0,100,350, etc.) or use the convenient reset button on the RER.
- 5 Set the movable test ring on the appropriate tester's (main or small) register so the test ring's zero (0) is aligned with the sweep hand. Record the odometer reading.

**NOTE:** It may be necessary at higher flow rates to secure the test ring to the tester with tape.

- 6 Unless a chart or the rate indicator of the RER is available, the flow rate must be established with either a stop watch or sweep second hand of a watch. (To determine a flow rate, open the appropriate valve on the tester; note the starting time on the watch and the valve opening position. Note the time again when the valve is shut off. Divide the time (in minutes) into the quantity of water recorded; this will yield the flow rate. Example: 35 gallons for 30 seconds (1/2 minute) is 70 GPM.
- 7 After opening the appropriate valve on the tester to the desired flow rate, run sufficient water for the sweep hand on the tested meter's register to make a minimum of one (1) complete revolution. Close the valve on the tester when the sweep hand is again at zero (0) on the movable test ring.

**CAUTION:** see step 3 on closing the valves.

**NOTE:** Care must be taken to avoid falling below a 20 PSI reading on the pressure gauge while testing at higher flow rates. This condition may cause air to develop in the water line, thus causing erroneous data to be obtained.

- 8 Read the sweep hand (and odometer, if necessary) on the meter being tested. If the quantities result in the test meter's sweep hand turning other than one (1) full sweep, the indicator marks on the movable test ring will not represent one per cent (1%). For example, if the sweep hand goes only 1/2 revolution, each mark represents two per cent (2%). (For 10 revolutions, each mark would represent .1%.) If the RER is used, divide the tested meter total by the RER total and multiply by 100 to achieve the percent registration.

## PREVENTIVE MAINTENANCE

The purpose of preventive maintenance is to ensure efficient operation and long life by detecting and correcting any condition that may damage the meter or cause it to fail. Maintenance intervals are a function of the water quality and operating flows experienced by the meter. Preventive maintenance includes periodic inspection, accuracy testing and cleaning procedures.

### Accuracy Curve

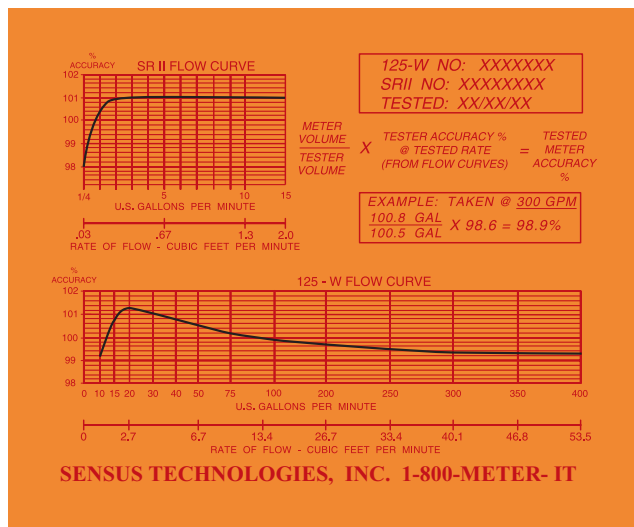

## Maintaining Accuracy

The accuracy of the 125-W and W-1250 Testers is verified and calibrated at the factory prior to shipment. Again, the easiest way to help insure the accuracy of the meter is through an established preventive maintenance program. However, after a long period of service, it may be necessary to return the tester to the factory for retest and recalibration.

**NOTE: It should be noted that the adjusting vane, located on an Sensus Turbo Meter's measuring chamber, is the device used to calibrate the meters accuracy. Care should be taken, during the preventive maintenance program, not to disturb the vane's setting. This will directly affect the tester's accuracy.**

## Warning Label

**WARNING**

- DO NOT LEAVE TESTER UNATTENDED DURING USE.
- DUE TO THRUST FROM TESTER, UNIT MUST BE PHYSICALLY RESTRAINED DURING USE OR INJURY MAY OCCUR
- DO NOT OPERATE TESTER ABOVE 150 PSI OR IF PRESSURE GAGE IS INOPERABLE.
- OPEN AND CLOSE VALVES SLOWLY TO PREVENT WATER HAMMER AND INSTABILITY OF TESTER
- USE MINIMUM 25' SUPPLY HOSE. HOSE MUST BE STRAIGHT DURING OPERATION USE OF A SHORTER HOSE OR CURVES IN HOSE COULD CAUSE TESTER TO BECOME UNSTABLE
- READ OPERATING INSTRUCTIONS BEFORE USE. (IF YOU DID NOT RECEIVE OPERATING INSTRUCTIONS, CONTACT YOUR SUPPLIER TO OBTAIN A COPY PRIOR TO OPERATING THIS UNIT.)

**Sensus Metering Systems – 1-800-METER-IT**

## RESETABLE ELECTRONIC REGISTER (RER)

The RER was exclusively designed for Sensus Test Meters. Accuracies of up to 100 times better than any direct read totalizing register, instantaneous rate flow and the ability to reset the totalizer to zero after each test sequence make the RER an unbeatable option for reliable straight forward meter testing.



## HIGH RESOLUTION TEST REGISTER

- Special gearing provides ten times (10X) standard resolution
- One sweep hand revolution equals 1/10 of a standard totalizer
- Conserves water by requiring less usage
- Easily installed for testing purposes
- Available on all sizes of Sensus SRM and SRH Compound Meters

