

Compact FireLine

4, 6, 8, 10-Inch Fire Service Assemblies

(Compact Fire Service) Bronze Magnetic Drive Size 10" (DN 250mm)

FIRELINE®

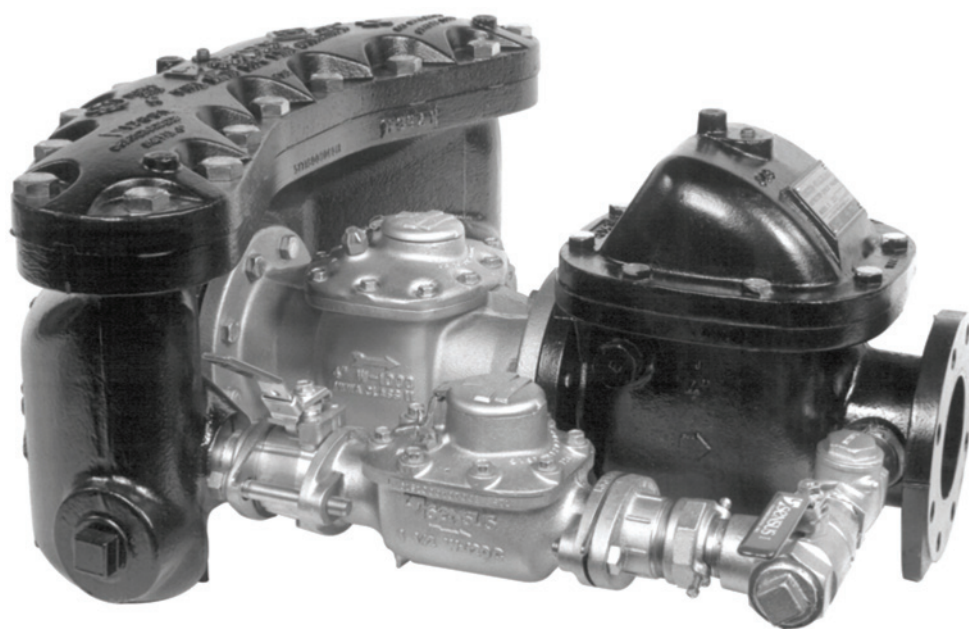

FireLine® Fire Service Meter Assemblies

Sizes:

4" (DN 100mm) x 1-1/2" (DN 40mm)

6" (DN 150mm) x 2" (DN 50mm)

8" (DN 200mm) x 2" (DN 50mm)

10" (DN 250mm) x 2" (DN 50mm)

COMPACT FIRELINE® FIRE SERVICE WATER METER ASSEMBLIES

Compact Sensus FireLine® Meter Assemblies save time and reduce installation costs by eliminating the need for a secondary service line in industrial, multi-residential and commercial applications. They can also be used in various manufacturing or processing applications where frequent high-capacity water flows are encountered.

FireLine Meter Assemblies with 1-1/2" and 2" Turbo Meters on the by-pass are UL Listed and FM approved. All Compact FireLine Meter Assemblies comply with ANSI/AWWA Standard C703 (most recent revision) and are individually performance tested to insure compliance.

Each Compact FireLine assembly includes a 4", 6", 8" or 10" size Sensus "W" Series Turbo Meter and strainer to measure high volume water flows, and a 1-1/2" or 2" Sensus "W" Series Turbo Meter to measure water flows within normal usage ranges. Whenever instantaneous high volume flow is required, such as when a building's automatic fire sprinkler or deluge system is activated, the Compact FireLine Meter Assembly automatically switches to its higher volume flow path. The high volume flows are measured by both meters as the water passes through the assembly.

Compact FireLine Meter Assemblies include all valves, meters, strainers and by-pass piping required. Each assembly is shipped completely assembled, ready to install.

Compact FireLine Fire Service Meter Assemblies are designed to be an exact replacement fit for inefficient or worn fire service meters having a short laying length.

Their specially designed fire service strainers help eliminate the need for digging extra deep pits or enlarging existing vaults for replacement applications. Compact FireLine Meter Assemblies can be ordered with optional electronic communication (ECR) registers for above-ground on-site or remote meter reading.

1. High Capacity Turbo Meter

Compact FireLine Meter Assemblies include a 4", 6", 8" or 10" "W" Series bronze Turbo Meter, proven in years of dependable service. Each is accuracy and pressure tested at the factory eliminating the need for adjustments in the field.

"W" Series Turbo Meters consist of two basic components; the maincase and a removable measuring chamber. Straightening vanes in the maincase minimize water "swirl" upstream of the meter, helping direct the flow evenly to the rotor.

"W" Series Turbo Meters feature a patented right angle magnetic drive. The only moving part exposed to water is the rotor assembly.

2. Compact Strainer

The patented compact V-shaped strainer screen is made of stainless steel and is designed to prevent debris or objects from damaging the meter's rotor or clogging the assembly. The compact strainer's narrow design body and lid are made of ductile iron. The removable lid provides easy access to the screen for routine inspection and maintenance.

3. Detector Check Valve

A gravity induced bronze clapper in the detector check valve directs any normal flow in the system through the smaller "regular strainservice" Turbo Meter and bypass. When full flow capacity is required, the clapper opens fully allowing unobstructed water flow.

4. Series "W" Turbo Meter On By-Pass

Each 4", 6", 8" and 10" Compact FireLine Meter Assembly includes either Model W-120 1/2" or Model W-160 2" Turbo Meter on the bypass to provide an operating range of from 4 to 160 gallons a minute (0.9 to 36. m³/h). Accuracy registration of the 2" or 1-1/2" Turbo Meter is 100% ±1.5% of actual throughput.

These meters feature a patented right angle magnetic drive which eliminates conventional worm or miter gears normally required for horizontally mounted rotors or turbine measuring elements. Each meter is factory tested to ensure years of trouble free service.

5. Check Valves

The valve is used to check or impede backflow in the line. Line pressure forces an internal disc to open, allowing water flow in the direction desired. When pressure drops, gravity and line backpressure close the disc, impeding backflow.

6. Ball Valves

Each Compact FireLine Meter Assembly includes two lockable ball valves; one upstream and one downstream of the normal service meter. Optional bronze gate valves are also available.

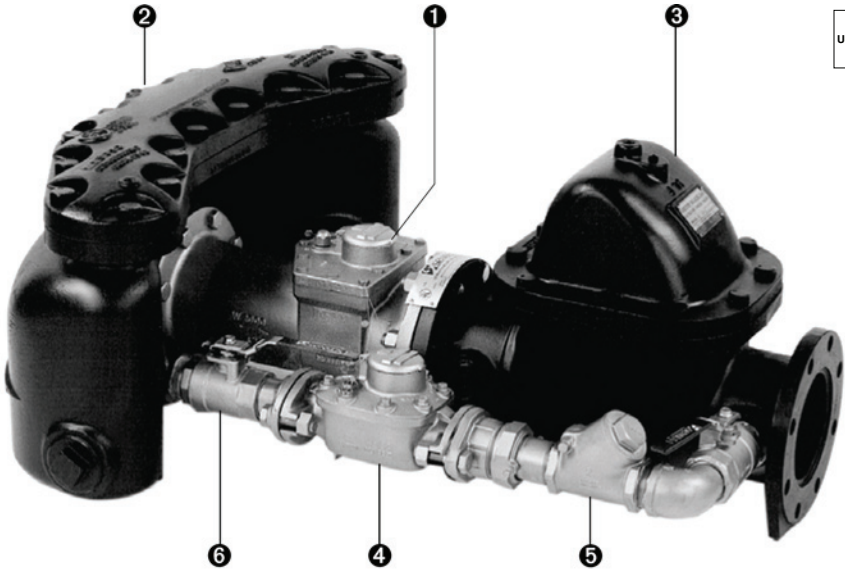

SPECIFICATIONS, MATERIALS AND DIMENSIONS

All Turbo Meters used in FireLine Meter Assemblies utilize hermetically sealed, direct read registers which are available in readouts of gallons, cubic feet, or metric units, as specified.

LIST OF MATERIALS – 4"

No.	Name	Quantity	Material
1	Sensus 4" Turbo Meter	1	Bronze
2	Compact Strainer	1	Ductile Iron
3	Sensus Detector Check Valve	1	Cast Iron
4	Sensus 1-1/2" Turbo Meter	1	Bronze
5	Check Valve	1	Bronze
6	Ball Valve — Locking ¹	2	Bronze
7	Upstream Bolts Supplied as Standard Equipment	8	Type 316 Stainless Steel
	4" Smith-Blair Flanged Coupling Adapter (Optional-Not Shown) ²	1	Cast Iron

DIMENSIONS – 4"

A	Laying Length	33.00"
B	Overall Height	16.25"
C	Center Line to Meter Base	4.50"
D	Center Line to Strainer Base	4.50"
E	Overall Width	35.00"
F	Center Line to Center Line	11.75"
G	Center Line to By-Pass Extreme Flanged Coupling Adapter Length	14.25"
	By-Pass Size (nom.)	1.50"
	Weight (Lbs)	480

FLOW RANGES AND ACCURACY LIMITS – 4"

4" Continuous Flows:	4 to 1000 GPM
Intermittent Flows:	1250 GPM
Low Flows:	3 GPM
Accuracy ³ :	±1.5% of Actual Throughput—95% at Low Flow

LIST OF MATERIALS – 6"

No.	Name	Quantity	Material
1	Sensus 6" Turbo Meter	1	Bronze
2	Compact Strainer	1	Ductile Iron
3	Sensus Detector Check Valve	1	Cast Iron
4	Sensus 2" Turbo Meter	1	Bronze
5	Check Valve	1	Bronze
6	Ball Valve — Locking ¹	2	Bronze
7	Upstream Bolts Supplied as Standard Equipment	8	Type 316 Stainless Steel
	6" Smith-Blair Special 913 Flanged Coupling Adapter (Optional-Not Shown) ²	1	Fabricated Steel

DIMENSIONS – 6"

A	Laying Length	45.00"
B	Overall Height	20.75"
C	Center Line to Meter Base	5.75"
D	Center Line to Strainer Base	5.75"
E	Overall Width	40.44"
F	Center Line to Center Line	11.34"
G	Center Line to By-Pass Extreme Flanged Coupling Adapter Length	14.25"
	By-Pass Size (nom.)	5.00"
	Weight (Lbs)	950

FLOW RANGES AND ACCURACY LIMITS – 6"

6" Continuous Flows:	4 to 2000 GPM
Intermittent Flows:	2500 GPM
Low Flows:	3 GPM
Accuracy ³ :	±1.5% of Actual Throughput—95% at Low Flow

¹ Bronze gate valve optional

² Pipeline OD required

³ Except at crossover

Electronic and remote reading registers are available. Consult your Sales Representative for more details.

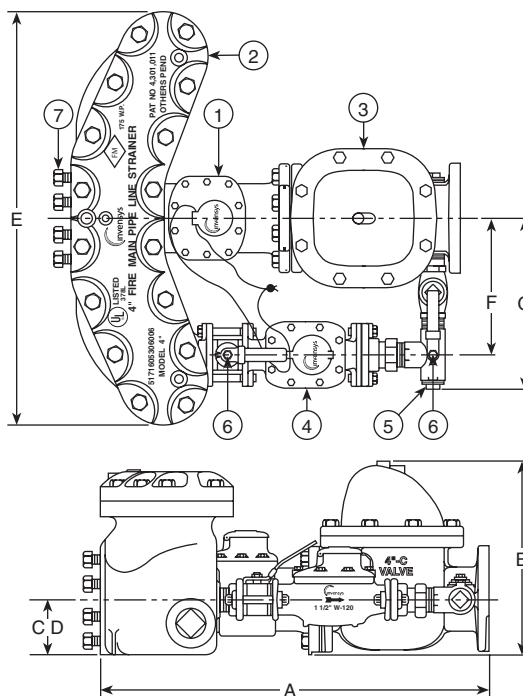

4"

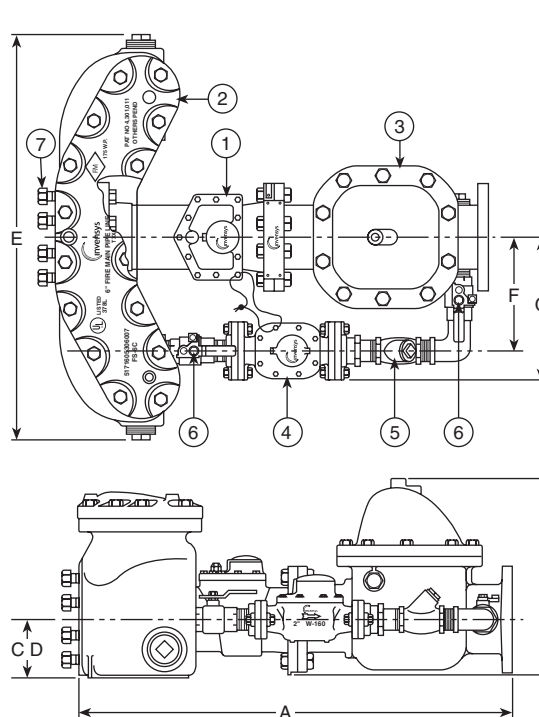

6"

SPECIFICATIONS, MATERIALS AND DIMENSIONS

All Turbo Meters used in FireLine Meter Assemblies utilize hermetically sealed, direct read registers which are available in readouts of gallons, cubic feet, or metric units, as specified.

LIST OF MATERIALS – 8"

No.	Name	Quantity	Material
1	Sensus 8" Turbo Meter	1	Bronze
2	Compact Strainer	1	Ductile Iron
3	Sensus Detector Check Valve	1	Cast Iron
4	Sensus 2" Turbo Meter	1	Bronze
5	Check Valve	1	Bronze
6	Ball Valve — Locking ¹	2	Bronze
7	Upstream Bolts Supplied as Standard Equipment	8	Type 316 Stainless Steel
8	8" Smith-Blair Special 913 Flanged Coupling Adapter (Optional-Not Shown) ²	1	Fabricated Steel

DIMENSIONS – 8"

A	Laying Length	53.00"
B	Overall Height	24.00"
C	Center Line to Meter Base	6.75"
D	Center Line to Strainer Base	6.75"
E	Overall Width	45.50"
F	Center Line to Center Line	13.65"
G	Center Line to By-Pass Extreme	17.00"
	Flanged Coupling Adapter Length	5.13"
	By-Pass Size (nom.)	2.00"
	Weight (Lbs)	1175

FLOW RANGES AND ACCURACY LIMITS – 8"

8"	Continuous Flows: 4 to 3500 GPM
	Intermittent Flows: 4400 GPM
	Low Flows: 3 GPM
	Accuracy ³ : ±1.5% of Actual Throughput–95% at Low Flow

LIST OF MATERIALS – 10"

No.	Name	Quantity	Material
1	Sensus 10" Turbo Meter	1	Bronze
2	Compact Strainer	1	Ductile Iron
3	Sensus Detector Check Valve	1	Cast Iron
4	Sensus 2" Turbo Meter	1	Bronze
5	Check Valve	1	Bronze
6	Ball Valve — Locking ¹	2	Bronze
7	Upstream Bolts Supplied as Standard Equipment	8	Type 316 Stainless Steel
10"	10" Smith-Blair Special 913 Flanged Coupling Adapter (Optional-Not Shown) ²	1	Fabricated Steel

DIMENSIONS – 10"

A	Laying Length	68.00"
B	Overall Height	28.13"
C	Center Line to Meter Base	8.50"
D	Center Line to Strainer Base	8.50"
E	Overall Width	50.00"
F	Center Line to Center Line	16.18"
G	Center Line to By-Pass Extreme	18.74"
	Flanged Coupling Adapter Length	5.56"
	By-Pass Size (nom.)	2.00"
	Weight (Lbs)	1840

FLOW RANGES AND ACCURACY LIMITS – 10"

10"	Continuous Flows: 4 to 5500 GPM
	Intermittent Flows: 7000 GPM
	Low Flows: 3 GPM
	Accuracy ³ : ±1.5% of Actual Throughput–95% at Low Flow

¹ Bronze gate valve optional

² Pipeline OD required

³ Except at crossover

Electronic and remote reading registers are available. Consult your Sales Representative for more details.

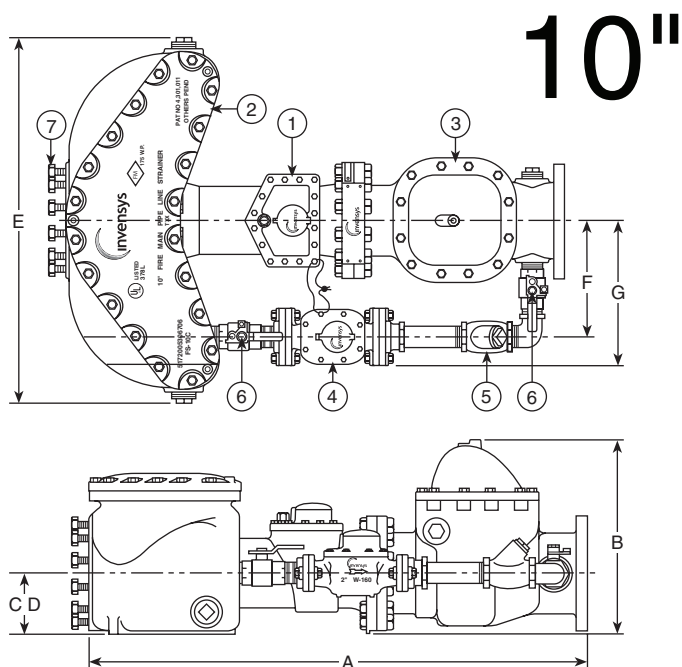
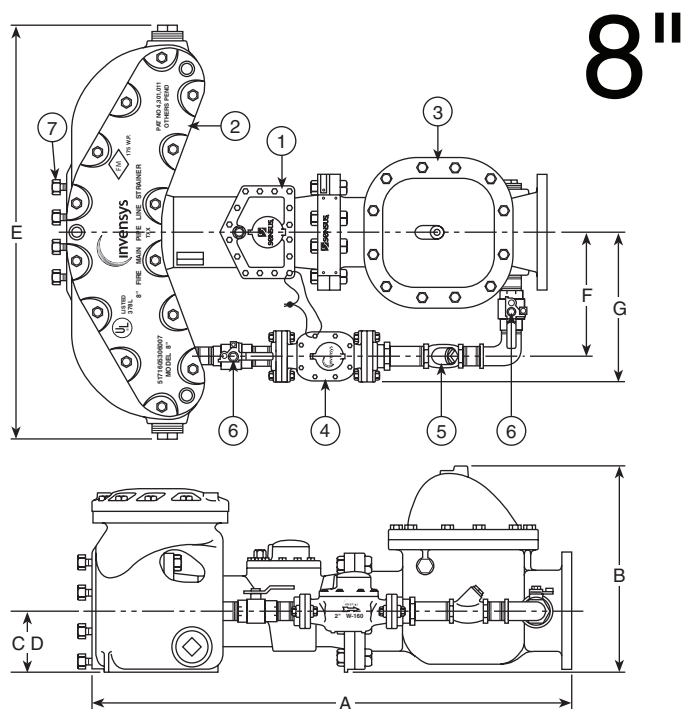

FIRELINE® METER ASSEMBLIES – ACCURACY AND HEAD LOSS CURVES

4"

Accuracy and Head Loss Curves

4" FireLine Assembly with 1-1/2" Bronze By-Pass and 1-1/2" W-120 Turbo Meter

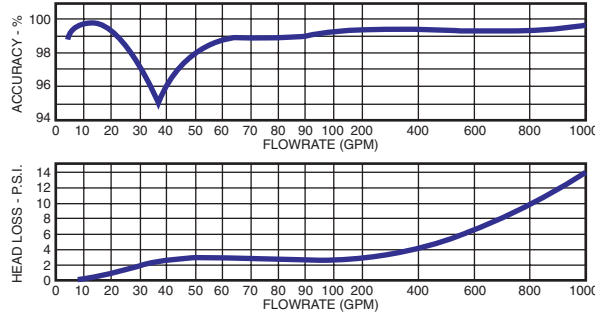

6"

Accuracy and Head Loss Curves

6" FireLine Assembly with 2" Bronze By-Pass and 2" W-160 Turbo Meter

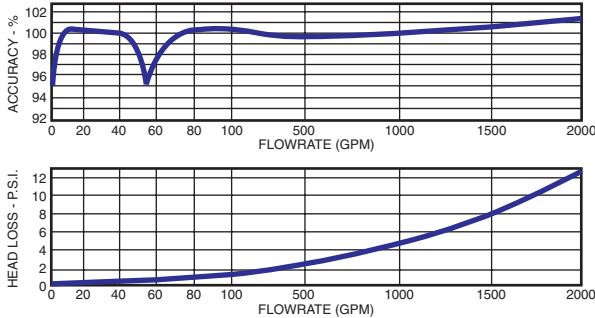

8"

Accuracy and Head Loss Curves

8" FireLine Assembly with 2" Bronze By-Pass and 2" W-160 Turbo Meter

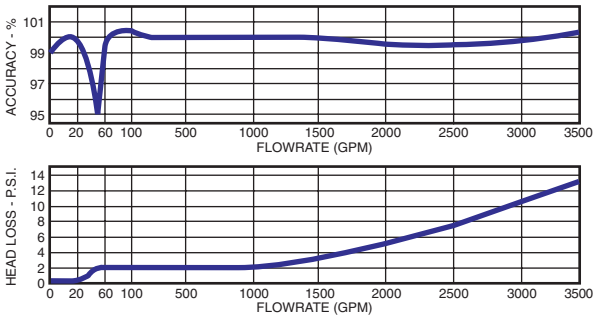

10"

Accuracy and Head Loss Curves

10" FireLine Assembly with 2" Bronze By-Pass and 2" W-160 Turbo Meter

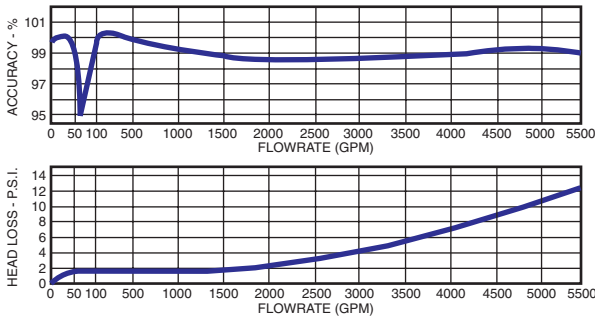

TOUCHREAD® SYSTEM

The fast, accurate, safe and efficient way to read underground vault-set water meters

TouchRead System registers and lid-mounted modules can be optionally added to your Sensus fire service or other underground meters to provide a faster, more efficient way to obtain readings from vault-set meters. The TouchRead System provides a realistic payback by eliminating many of the problems associated with reading underground meters—such as pumping out flooded vaults or sending two-person crews to comply with confined space safety regulations.



TouchRead equipped vault-set meters are read by touching the tip of a PitProbe reading gun to an electronic module mounted in the vault lid and depressing a button on the gun's handle. In about two seconds, each meter's reading data is electronically transferred to a hand held visual reader or Handheld device carried by the meter reader.

For more information, contact your Sensus representative or authorized distributor.

DUAL RANGE ACCURACY FROM A SINGLE SERVICE LINE

FireLine Meter Assemblies provide a dual range water flow path. During normal flow range usage, the flow travels through only the smaller line and is accurately measured by the 1-1/2" W-120 or 2" W-160 Turbo Meter.

For sudden high capacity flow requirements — such as when a building's automatic fire sprinkler or deluge system is activated, the assembly's detector check valve responds to the demand and automatically opens the flow path to include the large line. At high flow, both meters will be measuring and supplying water. No outside electronic switching devices are required.

