

# WKM DynaSeal 210 and 310 Floating Ball Valves

Industry-recognized flanged and threaded end floating ball valves  
for oilfield and industrial applications

TECHNOLOGY



## Table of Contents

### WKM DYNASEAL 210 AND 310 FLOATING BALL VALVES

#### WKM DynaSeal 210 Floating Ball Valves

How to Order .....	1
Features and Benefits .....	2
Exploded View and Specifications .....	4
Materials List .....	5
Dimensions and Weights .....	6

#### WKM DynaSeal 310 Floating Ball Valves

Trim Guidelines for All DynaSeal 310 Valves .....	7
How to Order .....	8
Features and Benefits.....	9
Exploded Views and Specifications	
• Socket Weld Ends .....	12
• Threaded Connections.....	13
• Flanged Connections .....	14
Materials List – Threaded and Flanged Ends .....	15

#### Dimensional Data – 4” Reduced Port and Smaller

1/4” Full Port through 4” Reduced Port:	
Flanged, Threaded and Socket Weld .....	16
Features and Benefits.....	18
Exploded Views and Specifications.....	21
Materials List .....	23

#### Dimensional Data – 4” Full Port and Larger

4” Full Port through 8” Reduced Port .....	24
Pressure/Temperature for All DynaSeal 310 Valves.....	26
Weights.....	29
Flow Characteristics.....	30
Stem Torques.....	31

#### WKM DynaSeal 210 and 310 Floating Ball Valves

Material Selection Guide.....	33
CAMSERV Services for Valves and Actuation .....	40
Trademark Information .....	41

# WKM DynaSeal 210 Floating Ball Valves

## HOW TO ORDER

J0XXXXX	-	2	1	X	X	X	0	X													
Base Part Number		Pressure Rating (CWP)	Body Material	Seat Trim	Seal Material	Ball and Stem		Handle													
Female Threaded Ends 750/1000# MOP			Ductile Iron 1		Buna 1 FKM 2			No Handle 0 Handle 1 No Handle with Seal Pin 2 Handle with Seal Pin 3													
<table border="1"> <thead> <tr> <th>Size</th> <th>Base Number</th> </tr> <tr> <th>in. (mm)</th> <th></th> </tr> </thead> <tbody> <tr><td>2 x 1-1/2 (50 x 40)</td><td>24925</td></tr> <tr><td>2 x 2 (50 x 50)</td><td>25144</td></tr> <tr><td>3 x 2 (80 x 50)</td><td>24926</td></tr> <tr><td>3 x 3 (80 x 80)</td><td>25145</td></tr> <tr><td>4 x 3 (100 x 80)</td><td>25154</td></tr> </tbody> </table>		Size	Base Number	in. (mm)		2 x 1-1/2 (50 x 40)	24925	2 x 2 (50 x 50)	25144	3 x 2 (80 x 50)	24926	3 x 3 (80 x 80)	25145	4 x 3 (100 x 80)	25154	750 psi 1 1000 psi 2 1500 psi 3 2000 psi 4	Acetal Plastic (43) 3 Filled Teflon (42) 5	Carbon Steel 1 Stainless Steel 2 Carbon Steel Unidirectional 3 Stainless Steel Unidirectional 4			
Size	Base Number																				
in. (mm)																					
2 x 1-1/2 (50 x 40)	24925																				
2 x 2 (50 x 50)	25144																				
3 x 2 (80 x 50)	24926																				
3 x 3 (80 x 80)	25145																				
4 x 3 (100 x 80)	25154																				

\* See page 4 for details.

### 1500/2000# MOP

1 x 1 (25 x 25)	24190
2 x 1-1/2 (50 x 40)	24132
2 x 2 (50 x 50)	24056
2-1/2 x 2 (65 x 50)	24059
3 x 2 (80 x 50)	24063
3 x 3 (80 x 80)	24178*
4 x 3 (100 x 80)	24211*

\* Maximum pressure rating of 1500 psi for 4" x 3" (100 mm x 80 mm) and 3" x 3" (80 mm x 80 mm).

### Grooved Ends 750# MOP

2 x 1-1/2 (50 x 40)	25111
3 x 2 (80 x 50)	25112
4 x 3 (100 x 80)	25113

**Examples:** Standard Trim 2" (50 mm) J024925-2131100  
 H<sub>2</sub>S, NACE Trim Suffix Code = standard -213220X  
 = unidirectional -213240X

NACE MR0175/ISO 15156 Compliance – Materials of construction shall be in compliance with the pre-qualified material requirements specified by NACE MR0175/ISO 15156. According to NACE MR0175/ISO 15156, it is the manufacturer's responsibility for meeting metallurgical requirements and the customer/user responsibility to ensure that a material will be satisfactory in the intended environment. When given the application requirements (environment) by the customer/user, Cameron can make technical recommendations in accordance with NACE MR0175/ISO 15156, but that in no way certifies or warrants the product or materials for the application.

## FEATURES AND BENEFITS

**This rugged yet economical ductile iron ball valve is ideal for threaded end oilfield applications where carbon steel body material is not a requirement.**

Cameron's WKM® DynaSeal™ 210 ball valve is a two-piece design with a ductile iron body and tailpiece. This valve is economical and includes many of the premium design features found in the WKM DynaSeal 310 carbon steel ball valve.

It is available in 1" to 4" x 3" (25 mm to 100 mm x 80 mm) sizes. Working pressures offered are 750, 1000, 1500 and 2000 psi. (See size/pressure table on page 5.)

This valve is used primarily in the oilfield market for the following applications:

- Production wing valves on low-pressure gas wells
- Production flowlines
- Production gathering systems for water, oil and gas
- Gas blowdown service
- Tank batteries for storage or production
- Frac water tanks

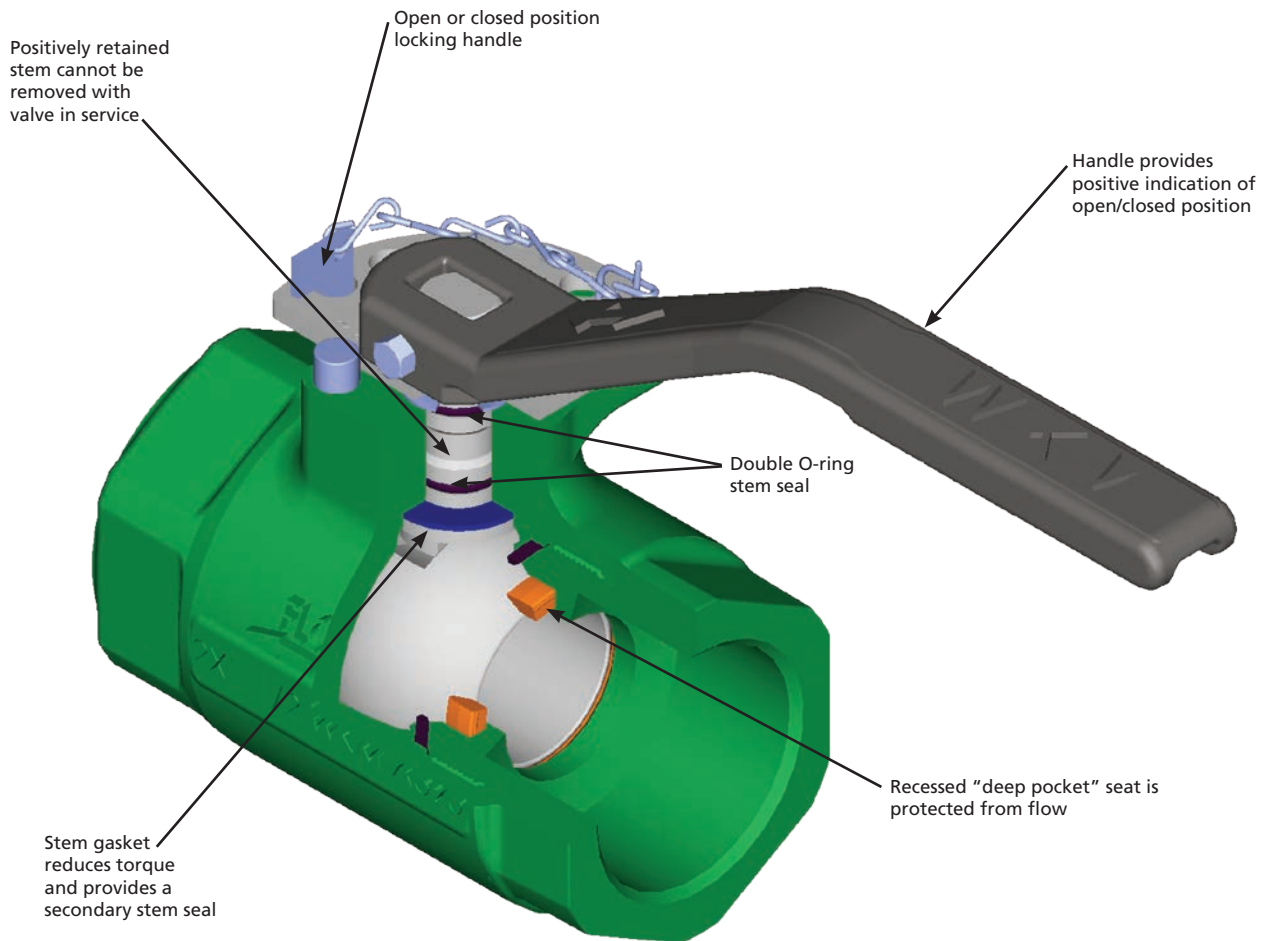



### Locking Capability is Standard

- The valve can be locked in the open or closed position.

### Positively Retained Stem

- The stem is positively retained. It is designed to prevent stem blowout while the valve is in service.

### Color-coded Working Pressures

The lock plates are color-coded so pressure ratings are quickly identified.

- 750/1000 psi: green
- 1500 psi: blue
- 2000 psi: red

### Unidirectional Ball (Option)

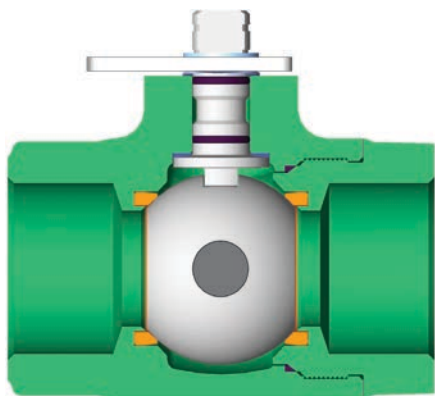

The WKM DynaSeal 210 unidirectional valve option provides relief to valves that might have water trapped in the body cavity and then are exposed to a temporary freeze. Since this option relies on a relief hole in the ball to relieve the excess pressure, the valve is stamped with a directional flow arrow to be sure the side of the ball with the hole is installed upstream.

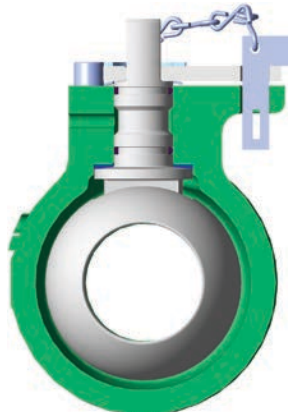
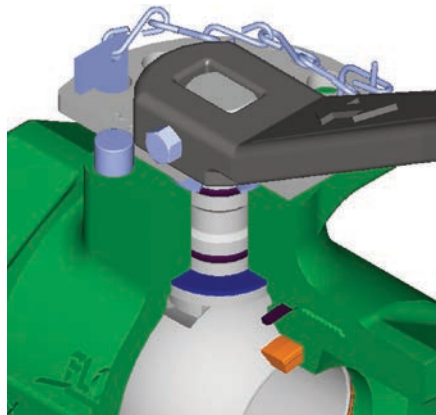
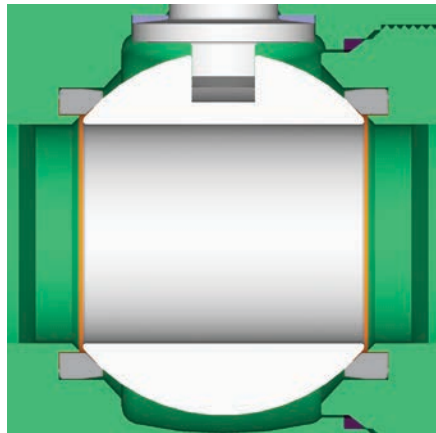

### Fire-tested Design

The WKM DynaSeal 210 ball valves are qualified under API Standard 607.

The deep-pocketed seat, locked in stem and body/tailpiece designs give this valve excellent fire-tested characteristics.

### Superior Stem Journal Design Prevents Stem Seizure

The stem is designed with two internal O-ring grooves located on either side of a shallow grease groove.

The top O-ring is a weather seal while the bottom one seals the stem bore against the line media. The stem gasket provides a backup seal.

The shallow groove between the O-rings provides three benefits:

- Prevents stem seizure
- Reduces torque
- Provides a space for lubricating grease applied at the factory during assembly

### TFE Body Seal

A TFE body seal is positioned between the line bore and tailpiece threads, isolating the threads from the line media.

### Deep Recessed Seats

The seat is recessed into a deep machined pocket, which serves to surround and protect the seat on all sides. This design eliminates cold flow into the valve conduit where it can be damaged by the action of the ball or the flow medium. The result is long and extended service life.

### Seal Pin Device Provided as Standard on 750 and 1000 psi; 2", 3" and 4" (50 mm, 80 mm and 100 mm) Reduced Port Valves

A secondary seal pin device for applying tamper detection is provided on these valves. They are a popular choice for production tank batteries where tamper detection often is required.

## SPECIFICATIONS

1" Full Port through 4" x 3" Reduced Port

### Standards and Specifications

WKM DynaSeal 210 ball valves conform to the following design and testing standards:

#### Standard Materials

- API line pipe threads
- Body: Ductile iron
- Ball and Stem: Carbon steel or stainless steel
- Seat and Seals: Acetal plastic/Buna-N

#### Optional Materials

- Ball and Stem: Stainless steel
- Seat and Seals: TFE/FKM

#### Compliances

- ASME B16.5
- MSS-SP-6, 25, 55, 72 and 61
- NACE MR0175/ISO 15156
- API 607 Fire-test Specification

### ASME Pressure Classes

Size			Classes			
in.	(mm)		750	1000	1500	2000
1	(25)	FP			•	•
2 x 1-1/2	(50 x 40)	RP	•	•	•	•
2	(50)	FP	•		•	•
2-1/2 x 2	(65 x 50)	RP			•	•
3 x 2	(80 x 50)	RP	•	•	•	•
3	(80)	FP	•	•	•	
4 x 3	(100 x 80)	RP	•	•	•	

### Unidirectional Ball (Optional)

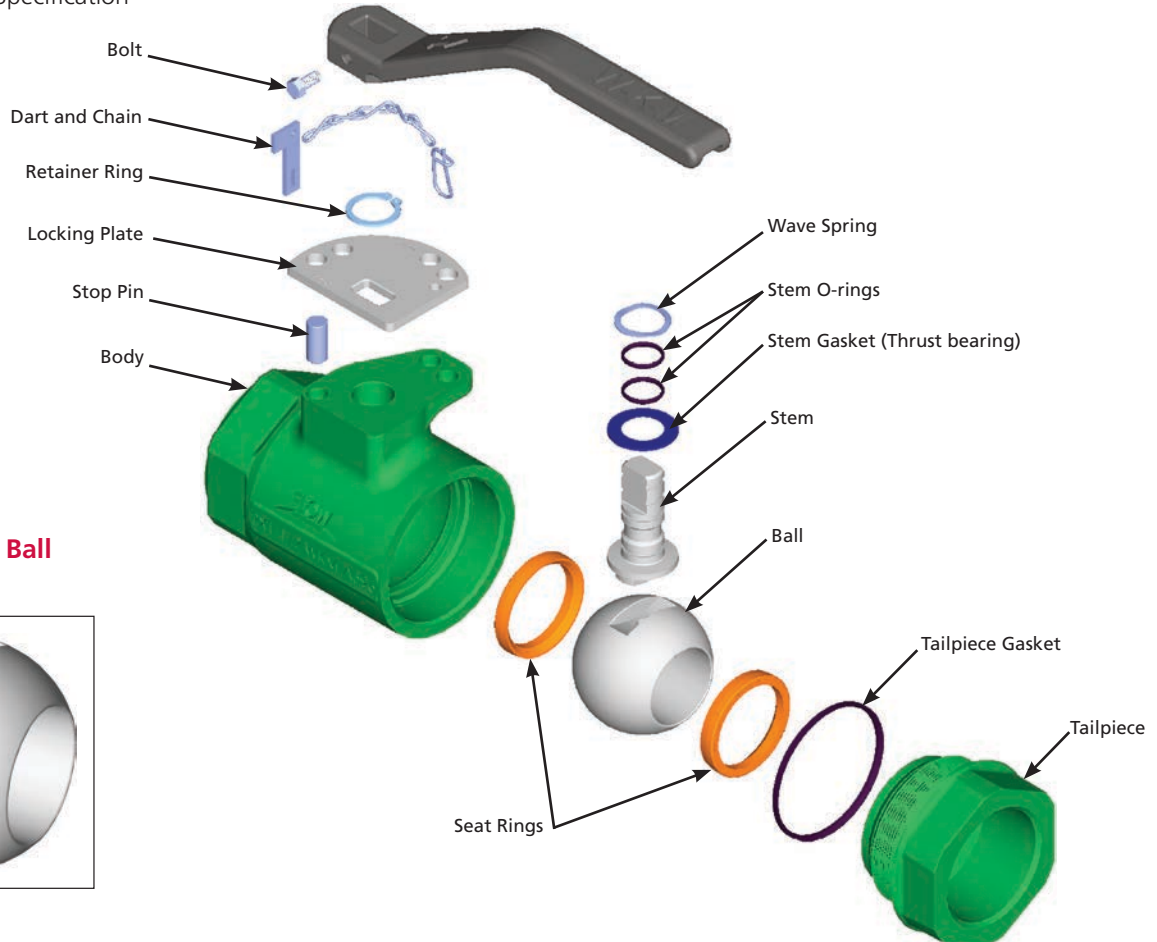
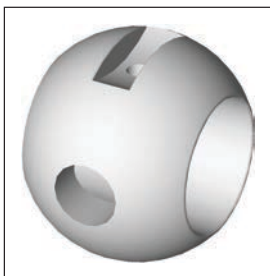

## MATERIALS LIST

1" Full Port through 4" x 3" Reduced Port

750, 1000, 1500 and 2000 psig Working Pressure

### Standard Materials

Qty.	Description	Material
1	Body	ASTM A395 Ductile Iron
1	Tailpiece	ASTM A395 Ductile Iron
1	Ball	Carbon Steel Chrome-plated 316 SS
1	Stem	AISI 1213/1215, Steel, Zinc-plated 316 SS (Type 630 on 2" x 1-1/2" (50 mm x 40 mm))
2	Seat Ring	Acetal Plastic (43) Filled TFE (42)
1	Tailpiece Gasket	PTFE
2	Stem O-ring	Buna-N FKM
1	Stem Gasket (Thrust Bearing)	Filled TFE
1	Locking Plate	Steel 1018/26
1	Locking Plate Retaining Ring	Spring Steel
1	Wave Spring	Spring Steel
1	Stop Pin	Spring Steel
1	Handle	ASTM A395 Ductile Iron
1	Seal Pin/Dart	Brass or Aluminum

NOTE: For H<sub>2</sub>S service, use Trim Code -X13220X. Meets NACE MR0175/ISO 15156 (see "How to Order" on page 2).

## DIMENSIONS AND WEIGHTS

### 1" Full Port through 4" x 3" Reduced Port

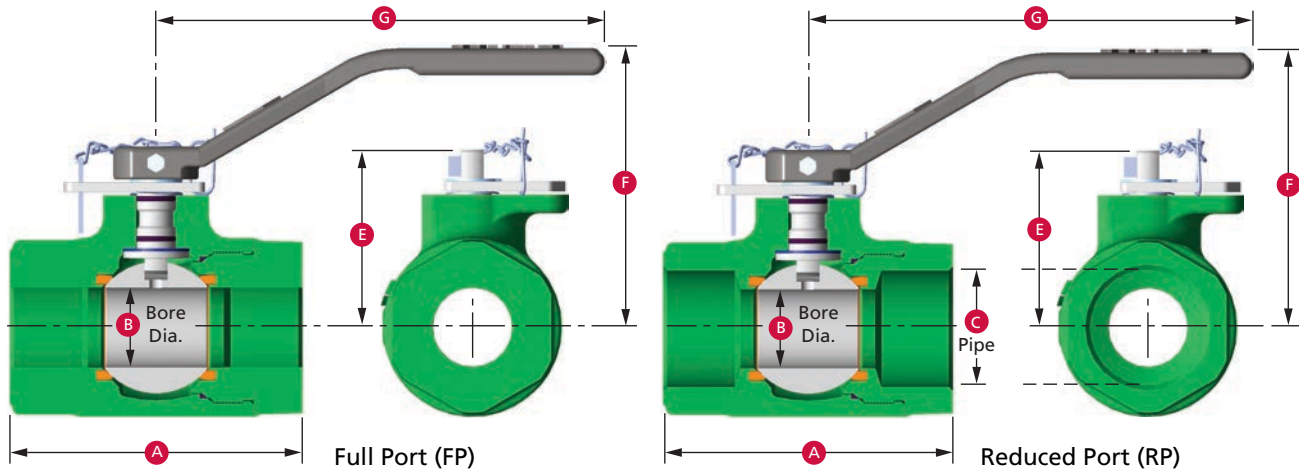

### Dimensions

Size in. (mm)	Dimension A		B	C	E	F	G
	Threaded	Grooved					
1 FP	4.00	–	1.00	1.00	2.77	4.0	7.1
(25 FP)	(102)	–	(25)	(25)	(70)	(102)	(180)
2 RP	5.55	5.25	1.50	2.00	3.56	4.9	7.1
(50 RP)	(141)	(133)	(38)	(50)	(90)	(124)	(180)
2 FP	6.00	–	2.00	2.00	4.50	4.9	15.0
(50 FP)	(152)	–	(51)	(50)	(114)	(124)	(381)
2-1/2 RP	7.00	–	2.00	2.50	4.50	4.9	15.0
(65 RP)	(178)	–	(51)	(65)	(114)	(124)	(381)
3 RP	7.25	7.25	2.00	3.00	4.50	4.9	15.0
(80 RP)	(184)	(184)	(51)	(80)	(114)	(124)	(381)
3 FP	8.75	–	3.00	3.00	5.66	6.0	15.0
(80 FP)	(222)	–	(76)	(80)	(144)	(152)	(381)
4 RP	8.75	8.88	3.00	4.00	5.66	6.0	15.0
(100 RP)	(222)	(226)	(76)	(100)	(144)	(152)	(381)

NOTE: The dimensions are approximated.

### Weights – Full Port

Operation	Valve Size (in.) and Weight (lb)		
	1 x 1	2 x 2	3 x 3
Without Handle	4.0	14.4	42.8
With Handle	4.5	17.6	46.0
Operation	Valve Size (mm) and Weight (kg)		
	25 x 25	50 x 50	80 x 80
Without Handle	1.8	6.5	19.4
With Handle	2.0	8.0	20.9

### Weights – Reduced Port

Operation	Valve Size (in.) and Weight (lb)			
	2 x 1-1/2	2-1/2 x 2	3 x 2	4 x 3
Without Handle	9.4	15.5	16.6	35.5
With Handle	9.9	18.0	19.8	38.7
Operation	Valve Size (mm) and Weight (kg)			
	50 x 40	65 x 50	80 x 50	100 x 80
Without Handle	4.3	7.0	7.5	16.1
With Handle	4.5	8.2	9.0	17.6



# WKM DynaSeal 310 Floating Ball Valves

## TRIM GUIDELINES FOR ALL DYNASEAL 310 VALVES

This chart is an abbreviated guide to the chemical resistance and pressure/temperature limitations of the seal materials used in the WKM DynaSeal 310 floating ball valve. Consult Cameron regarding questions about trim selections.

Seal Code	Seat Material	Tailpiece Gasket	Service Application
01	TFE	TFE	Seat and tailpiece gaskets are of virgin TFE. Use where lading contamination from glass or other fillers is not desirable, such as in food service. Recommended for low-temperature service to -50° F (-46° C). Also recommended for vacuum service.
42	Filled TFE	TFE	Seat material is TFE filled with inert materials for use at elevated temperatures and pressures. Same chemical resistance as virgin TFE except slightly affected by hot concentrated alkaline solutions. Some chlorinated compounds can cause swelling. Good for vacuum service. Also recommended for low-temperature service -50° F (-46° C).
43	Homopolymer Acetal Plastic	TFE	For general use at high pressures to a temperature of 220° F (104° C).
48	Homopolymer Acetal Plastic	Filled TFE	For general use at high pressures to a temperature of 220° F (104° C). Used on socket weld end valves 3" (80 mm) bore size and smaller. High- and low-pressure block-and-bleed.
07	*FKM/SS	TFE	General use for low-pressure and abrasion resistance. Not suitable for steam. Good for vacuum service. Available in bore sizes to 3" (80 mm).
18	HPT-2	Filled TFE	HPT-2 is a special TFE formulation for use at temperatures above trim 42 capability. Best suited for constant temperature or constant pressure applications. Proven service in steam, hot oil, heat transfer fluids, hot resins and boiler feed water. Same chemical resistance as TFE. Slightly affected by hot, concentrated alkaline solutions. Some fluorinated compounds cause swelling.
23	Celcon	TFE	For use in high-pressure applications. Temperature limited to 225° F (107° C) (1/4" to 3/4" (8 mm to 20 mm) bores only).
28	Filled TFE	Filled TFE	Same as 42, except tailpiece gasket is filled TFE. Used on weld end valves 4" (100 mm) and larger.
60S	Nickel Alloy HVOF/316	Graphite	Metal-to-metal QPQ ball and seat made of nickel alloy over 316 SS.
92H	Chrome Carbide/316	Graphite	Metal-to-metal ball and seat made of chrome carbide over 316 SS.

NOTE 1: Trim 07 and 18 should be tested for each application by actual use.

NOTE 2: All seal codes, with the exception of 07, have been fire-tested (and qualified) to API 607 4th edition requirements.

\* Trim sizes smaller than 1-1/2" (40 mm) in trim 07 are 100% elastomeric. Sizes 1-1/2" (40 mm) and larger are elastomeric with a metal insert.

## HOW TO ORDER

2	R	B	1	X	X	C	S	4	3	S	2	W	R
Size (in.)	Port Reduced Port = R Full Port = F	Valve Type*			Body Tailpiece Code		Seal Code		Ball and Stem Code		Actuator Code		

\* See chart below.

† Not all trim combinations are possible.

Consult factory for availability and for materials not listed.

Material	Codes
Carbon steel	CS
Controlled hardness carbon steel for H <sub>2</sub> S service	CS2*
Same as CS2, but special for -50° F (-46° C) service	CS3*
316 stainless steel for wetted parts	S1
316 stainless steel with stainless steel external trim; good for -50° F (-46° C)	S8*

\* Meets NACE \*MR0175/ISO 15156.

Material	Code
Carbon steel	CS
316 Stainless steel	S1
Type 630	S2*

\* NACE 4" (100 mm) RP and smaller.  
Type 630 stem, 316 stainless steel ball.

Seal Number	Seal Material	Tailpiece Gasket Material
01	PTFE	PTFE
42	Filled PTFE	PTFE
43	Homopolymer Acetal Plastic	PTFE
07	FKM	PTFE
18	HPT-2	Filled PTFE
23	Celcon	PTFE
28	Filled PTFE	Filled PTFE
60S	316 w/Nickel Alloy HVOF	Graphite
92H	316 w/Chrome Carbide	Graphite

Actuator Code	
Wrench*	WR
Oval Handwheel	OH
Worm Gear	WG
Bare Stem	BS
Less Gear	LG
Less Wrench	LW

\* Wrenches are part of the valve assembly on 4R bore and smaller valves. In 4" F through 8" x 6" (100 mm F through 200 x 150 mm), they are sold separately.

### 310 Two-piece Valve Type

Size in. (mm)	150 RF		300 RF		600 RF	600 RJ
	LP	SP	LP	SP		
1 (25)	FP	B110	-	B128	-	B182 B172
1-1/2 (40)	FP	B110	-	B128	-	B182 B172
2 (50)	RP	B100	-	B120	-	B114 B170
2 (50)	FP	B110	-	B128	-	B182 B172
3 x 2 (80 x 50)	RP	B100	-	B120	-	B114 B170
3 (80)	FP	B110	-	B128	-	B182 B172
4 (100)	RP	B100	-	B120	-	B114 B170
4 (100)	FP	B110	-	B128	-	B182*** B172***
6 (150)	RP	-	B102	B120	-	B114*** B170***
6 (150)	FP	B110	B113	B128	-	B182*** B172***
8 (200)	RP	B100	B102	-	B122	B114*** B170***

\*\*\* The 4" (100 mm) and larger sizes are available in trim CS2-43-S2-WGA (worm gear-operated) only.

### 310 Two-piece Valve Type

Size in. (mm)		Female Thread		Male X Female
1/4 (8)	FP	B138	-	-
3/8 (10)	FP	B138	-	-
1/2 (15)	RP	B136	-	-
1/2 (15)	FP	B138	-	-
3/4 (20)	FP	B138	-	B138 (M x F)**
1 (25)	RP	B136	-	B136 (M x F)**
1 (25)	FP	B138	-	-
1-1/2 (40)	FP	B138	-	-
2 (50)	RP	B136	-	-
2 (50)	FP	B138	-	-
3 (80)	RP	B138	-	-
3 (80)	FP	B138	-	-
4 (100)	RP	B136	-	-

\*\* Available in body tailpiece code S8 only.

NOTE: Threaded end valves have NPT internal pipe thread in full conformance with ASME B2.1 and Federal Thread Handbook H-28.

NACE MR0175/ISO 15156 Compliance – Materials of construction shall be in compliance with the pre-qualified material requirements specified by NACE MR0175/ISO 15156. According to NACE MR0175/ISO 15156, it is the manufacturer's responsibility for meeting metallurgical requirements and the customer/user responsibility to ensure that a material will be satisfactory in the intended environment. When given the application requirements (environment) by the customer/user, Cameron can make technical recommendations in accordance with NACE MR0175/ISO 15156, but that in no way certifies or warrants the product or materials for the application.

### 310 Three-piece Valve Type

Size in. (mm)			Socket Weld
1/4 (8)	FP	B103	B103
3/8 (10)	FP	-	-
3/4 (20)	FP	B103	B103
1 (25)	RP	B106	B106
1-1/2 (40)	FP	B103	B103
2 (50)	RP	B106	B106

## FEATURES AND BENEFITS

A premium quality floating ball valve that has proven itself in a wide variety of oilfield, chemical, petrochemical and hydrocarbon processing applications.

### Threaded Valve Assembly 1/4" Full Port through 4" x 3" Reduced Port

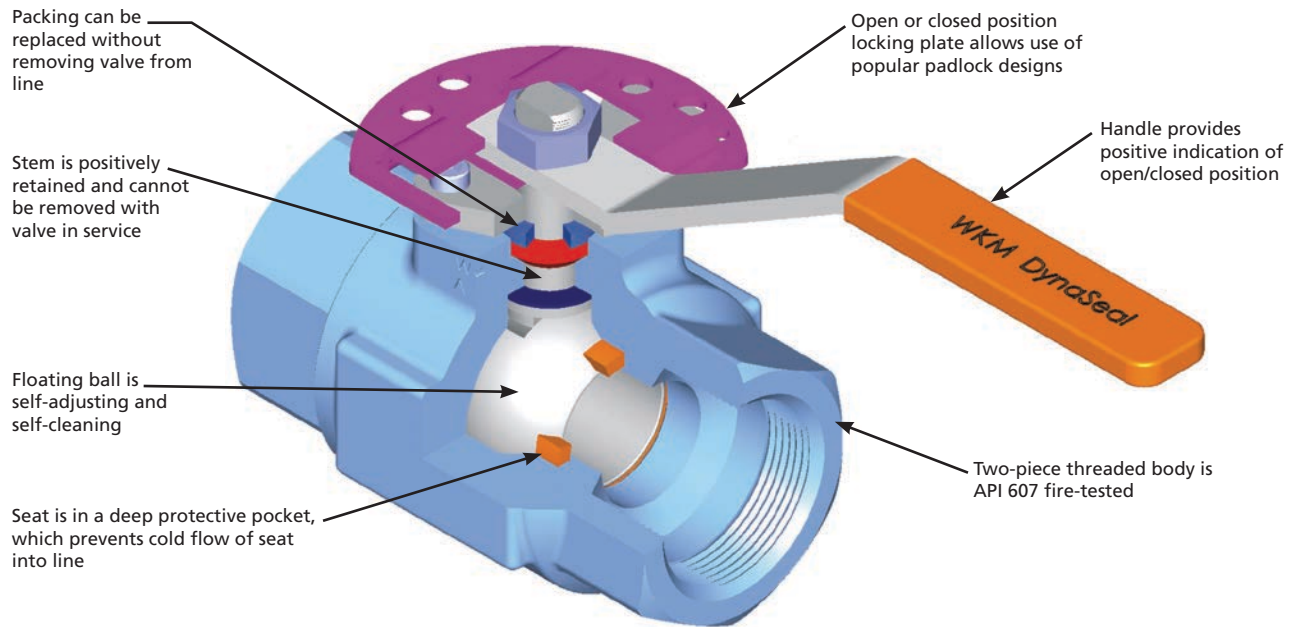

### Flanged Valve Assembly 1" Full Port through 4" x 3" Reduced Port

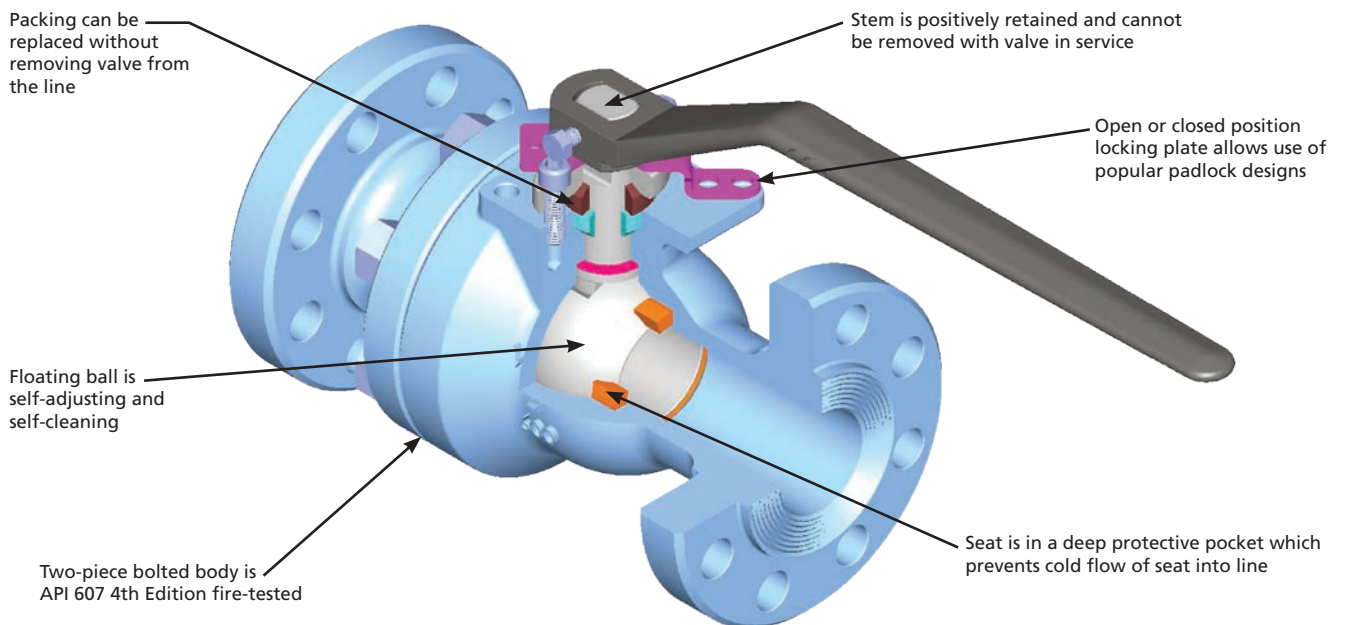

## FEATURES AND BENEFITS (CONTINUED)

WKM DynaSeal 310 floating ball valves satisfy a wide range of applications and are available in a variety of standard and optional materials, in sizes from 1/4" (8 mm) to 4" x 3" (100 mm x 80 mm) and working pressures to 5000 psi. Engineered for heavy-duty, maintenance-free performance, the DynaSeal 310 ball valve is preferred for use in critical applications.

### Sour Oil and Gas Service

WKM DynaSeal ball valves are suited to applications within gathering lines, manifolds and field processing units in sour oil and gas fields. They can be trimmed to conform with NACE MR0175/ISO 15156.

### Deep-recessed Seats

The WKM DynaSeal 310 seat is protected in a machined recess or deep pocket that surrounds and protects the seat. This design eliminates cold flow into the valve conduit and avoids potential seat damage from ball movement or flow media.

### Trim 42 Seats

Seats are manufactured of filled TFE and rated to 1500 psi MOP. With working temperatures to 500° F (260° C) and low-torque operation, these seats satisfy even the most difficult of processing requirements.

### Trim 43 Seats

Seats are manufactured of acetal plastic and are rated to 3000 psi MOP and working temperatures to 220° F (104° C). These seats are designed to handle the most demanding applications. They can flex under pressure and provide a consistent range of low-torque operations. They also provide a full face seal against the ball and multiple seals against the top and back of the pocket to provide a positive seal.

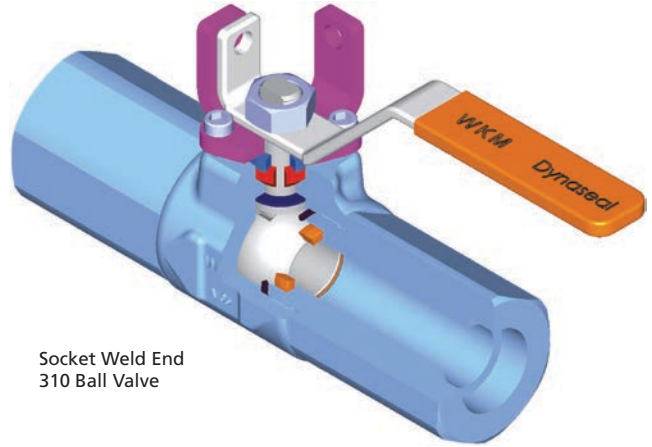

Socket Weld End  
310 Ball Valve

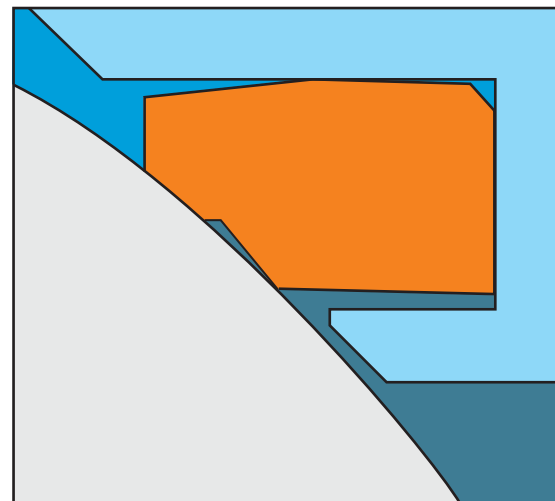
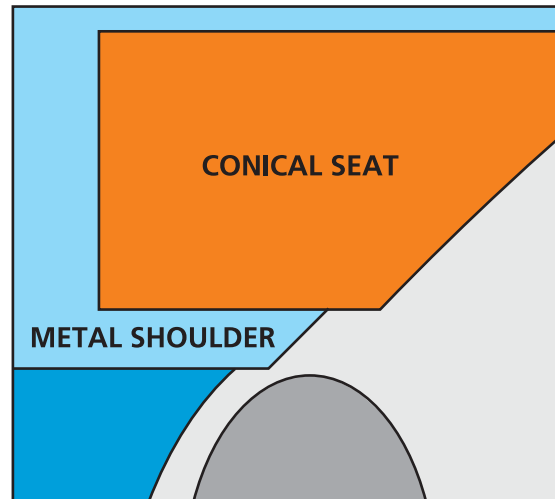

### Adjustable, Replaceable Packing

The in-line valve stem packing consists of PTFE impregnated graphite with an impervious metal barrier and a secondary tapered metal backup. The packing is field-adjustable and never requires lubrication. The packing and the stainless steel cap can be replaced without removing the valve from the line.

### Positively Retained Stem

The stem is positively retained with a shoulder. It cannot be removed with the valve in service. There are no O-rings used in this design.

### Floating Ball Design Delivers Tight Seal

The ground and polished ball is free to float and mates perfectly with the conical seats for a positive, leakproof seal. Self-cleaning and self-adjusting, the ball also is pressure activated – the higher the line pressure, the tighter the seal.

### Fire-tested for Safety

All WKM DynaSeal 310 ball valves are qualified under API Standard 607. The pocketed seat and locked-in stem design contributes to its fire-tested characteristics. Should the soft seats be destroyed by fire, the ball floats down stream, providing a tight metal-to-metal seal against the lip of the seat pocket. If the tailpiece seals are destroyed, the metal-to-metal tailpiece-to-body connection retards external leakage.

### Indicator Handle

The design of the handle permits installation on the stem in the correct position only, in alignment with the ball port. When the handle is aligned with the pipe, the valve is open. When the handle is perpendicular to the pipe, the valve is closed.

### Locking Devices

Locking devices are standard on all 4" x 3" (100 mm x 80 mm) and smaller manually operated valves and permit locking in either the open or closed positions.

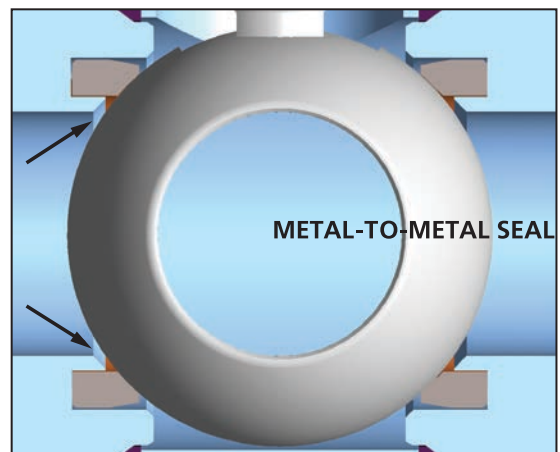
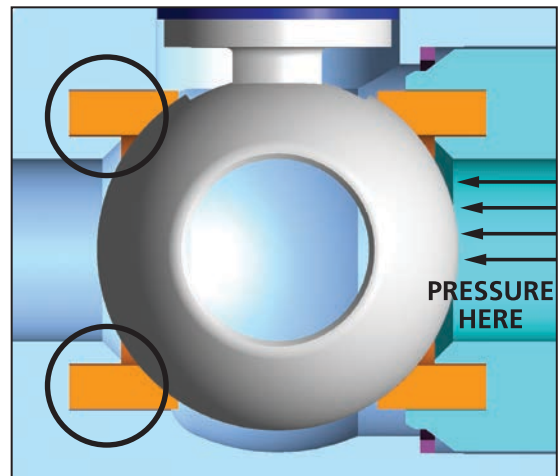
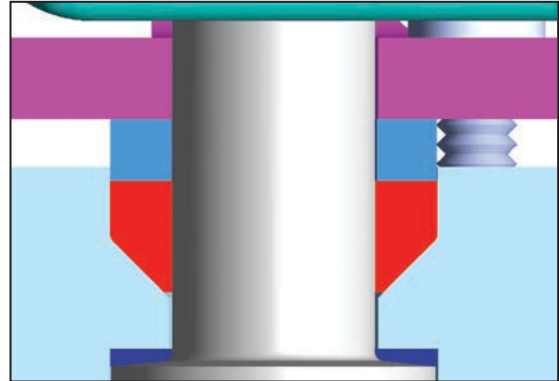



## SPECIFICATIONS

### Socket Weld Ends

#### Standards and Specifications

##### Sizes

- 1/4" (8 mm) full port
- 3/4" (20 mm) full port
- 1" (25 mm) reduced port
- 1-1/2" (40 mm) full port
- 2" (50 mm) reduced port

##### Working Pressure

- 3000 psi with trim 48

##### Operating Temperatures

- From -20° F to 220° F (-29° C to 104° C)

##### End Connections

- Socket weld ends

#### Standard Material

##### Body

- Carbon steel and carbon steel NACE MR0175/ISO 15156

##### Ball/Stem

- Carbon steel or stainless steel

##### Seats

- Trim 48 (acetal plastic seats)

#### Industry Standards Compliance

- ASME B16.34
- MSS-SP-25, 55, 72
- API 607 Fire-test Specification

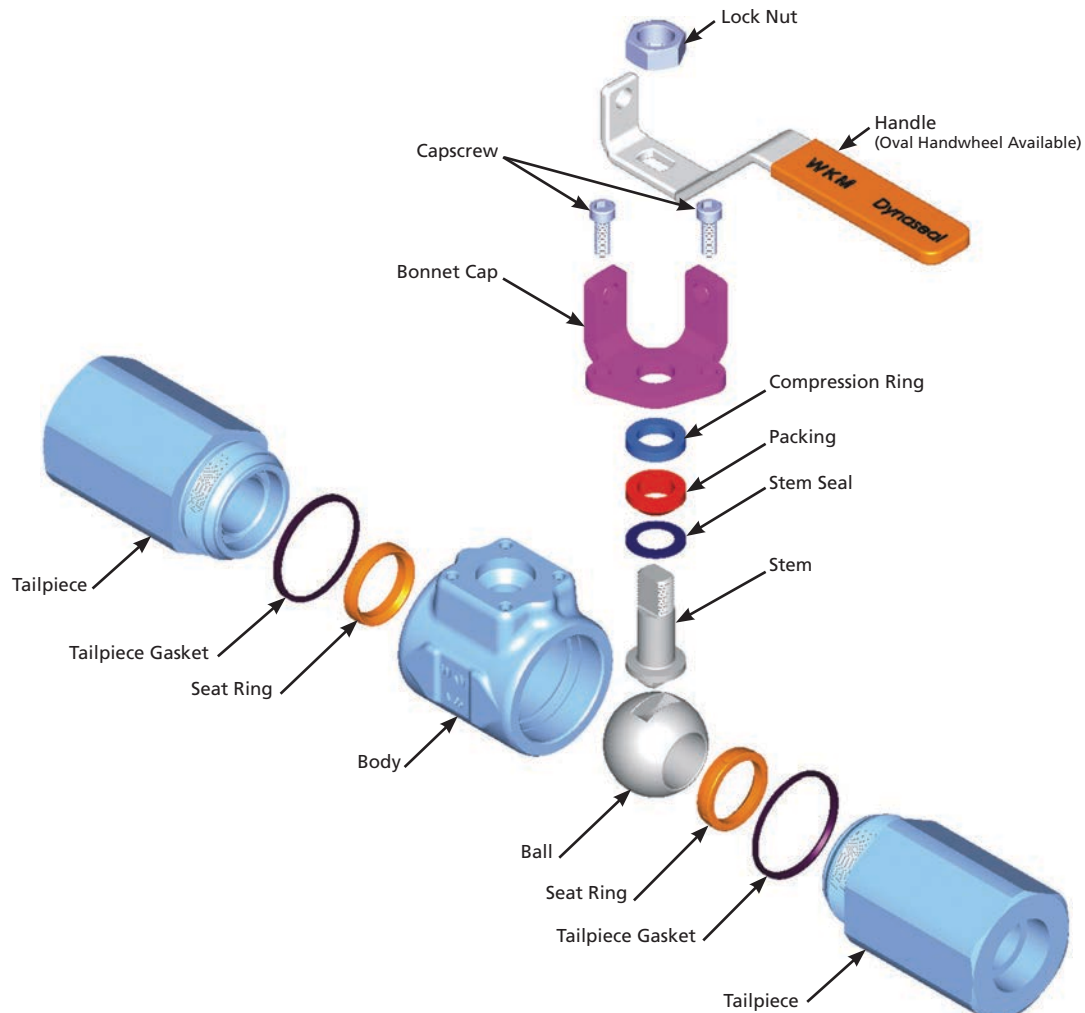

## Threaded Connections

### Standards and Specifications

- To 5000 psi in small sizes
- Trim 43 pressure range to 3000 psi in 1/4" (8 mm) to 3" x 2" (80 mm x 50 mm) threaded end valves

### Operating Temperatures

- From -50° F to 600° F (-46° C to 316° C)

### Standard Material

#### Body

- Carbon steel and stainless steel

#### Ball/Stem

- Carbon steel and stainless steel

#### Seat/Seal Trims

- TFE, filled TFE, acetal plastic, HPT-2 and 316 stainless steel with chromium carbide and FKM

### Industry Compliance

- ASME B16.5, B16.34
- MSS-SP-6, 25, 55, 72
- API 607 Fire-test Specifications
- GOST-R

### Threaded Connections

Full Port Size		Reduced Port Size	
in.	(mm)	in.	(mm)
1/4	(8)	1/2	(15)
3/8	(10)	1	(25)
1/2	(15)	2	(50)
3/4	(20)	3	(80)
1	(25)	4	(100)
1-1/2	(40)		
2	(50)		
3	(80)		

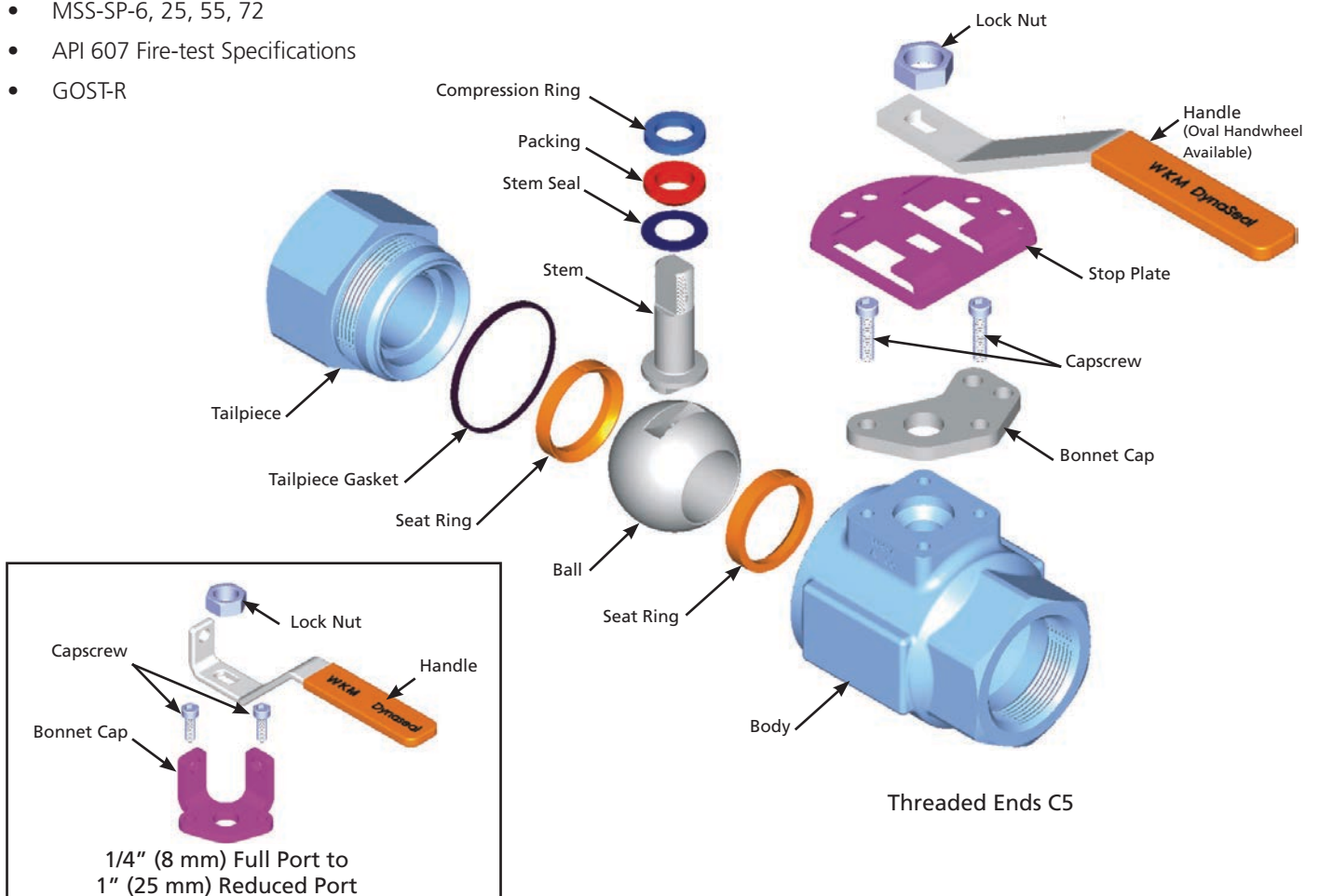

## SPECIFICATIONS

### Flanged Connections

#### Operating Temperatures

- From -50° F to 600° F (-46° C to 316° C)

#### Standard Material

##### Body

- Carbon steel and stainless steel

##### Ball/Stem

- Carbon steel and stainless steel

##### Seat/Seal Trims

- TFE, filled TFE, acetal plastic, HPT-2 and 316 stainless steel with chromium carbide and FKM

#### Industry Compliance

- ASME B16.5, B16.34
- MSS-SP-6, 25, 55, 72
- API 607 Fire-test Specifications
- GOST-R

#### Flanged Connections ASME Pressure Class

Size			Class		
in.	(mm)		150	300	600
1	(25)	FP	•	•	•
1-1/2	(40)	FP	•	•	•
2 x 1-1/2	(50 x 40)	RP	•	•	•
2	(50)	FP	•	•	•
3 x 2	(80 x 50)	RP	•	•	•
3	(80)	FP	•	•	•
4 x 3	(100 x 80)	RP	•	•	•

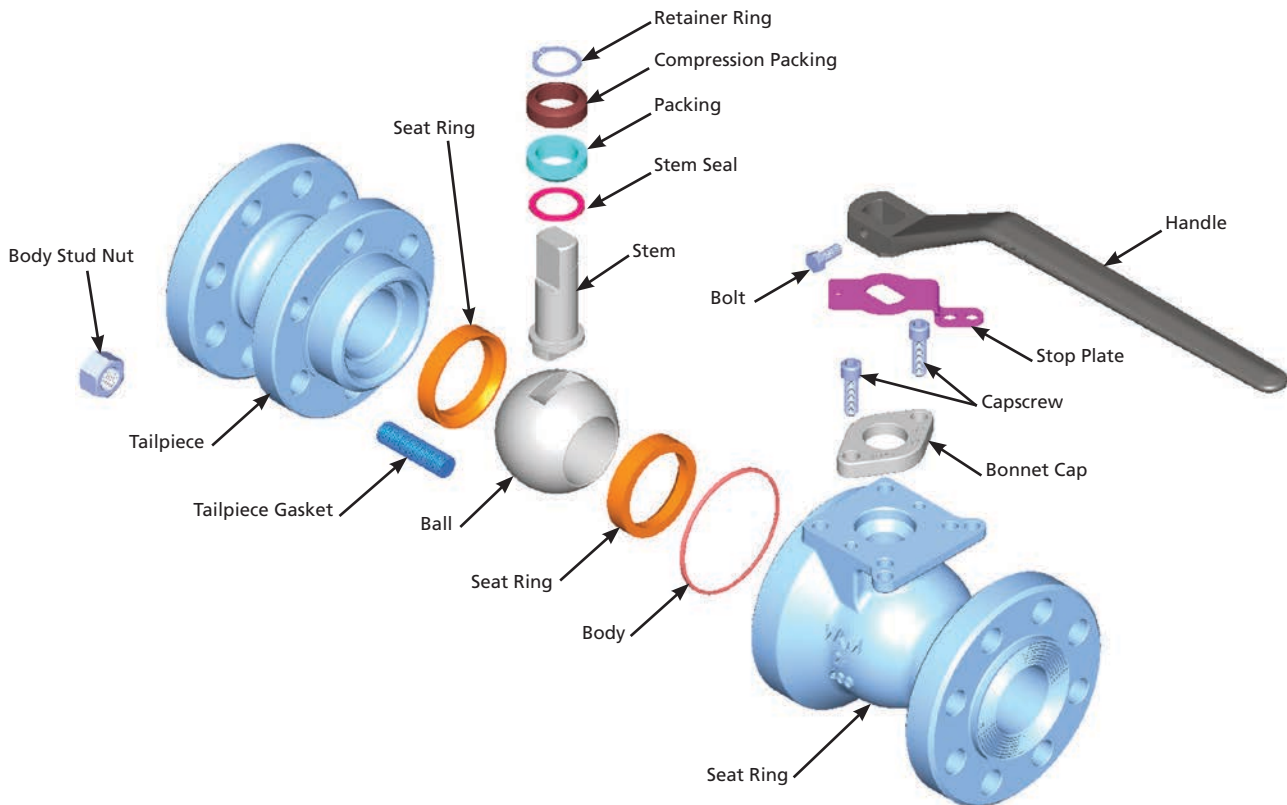

Flanged Ends 310F

## MATERIALS LIST – THREADED AND FLANGED ENDS

### 1/4" Full Port through 4" Reduced Port

#### Body / Tailpiece Material Code

Part	CS	CS2*	CS3*	S8*
Body	ASTM A105/A216 Gr. WCC	ASTM A105/A216 Gr. WCC	ASTM A350 LF2	316 SS/A351 CF8M
Studs	A193 Gr. B7	A193 Gr. B7M	A320 Gr. L7M	A193 Gr. B8
Nuts	A194 Gr. 2H	A194 Gr. 2HM	A194 Gr. 7ML	A194 Gr. 8
Body plug**	Carbon Steel	Carbon Steel	Carbon Steel	Stainless Steel
Tailpiece	ASTM A105/A216 Gr. WCC	ASTM A105/A216 Gr. WCC	ASTM A350 LF2	316 SS/A351 CF8M
Nameplate	Stainless Steel	Stainless Steel	Stainless Steel	Stainless Steel
Bonnet cap	Carbon Steel	Carbon Steel	Carbon Steel	Stainless Steel
Packing adjusting screws	Alloy Steel-plated	18-8 SS	18-8 SS	18-8 SS

\* CS2/CS3/S8 to be used for H<sub>2</sub>S service with S2 internal trim only. Meets NACE MR0175/ISO 15156.

\*\* When body drain is specified.

#### Seat Seal Material Code

Part	01	42	43	48***	07	18	60S
Seat	TFE	Filled TFE	Acetal Plastic	Acetal Plastic	FKM	Special Filled TFE	316/HVOF Nickel -
Tailpiece gasket	TFE	TFE	TFE	Filled TFE	TFE	Filled TFE	Graphite
Stem Seal	TFE	Filled TFE	Filled TFE	Filled TFE	Filled TFE	Filled TFE	Graphite
Packing	Graphite/TFE w/SS Cap						

\*\*\* Socket weld end valves only.

#### Ball / Stem Material Code

Part	CS	S1	S2*	60S
Ball	AISI 1213 CS Chrome Plate	316 Stainless Steel	316 Stainless Steel	316 QPQ Nitride
Stem	AISI 1213 Zinc Plate	316 Stainless Steel	Type 630	Type 630
Compression Ring	304 Stainless Steel	304 Stainless Steel	304 Stainless Steel	304 Stainless Steel

\* S2 trim (Type 630 stem and 316 SS ball) is required for H<sub>2</sub>S service per NACE MR0175/ISO 15156 to be used with body/tailpiece codes CS2/CS3/S8.

#### Actuator Code

Part (Body)	CS	CS2	CS3	S1	S8
Lock Nut*	Alloy Steel	Alloy Steel	Alloy Steel	Alloy Steel	Stainless Steel
Handle*	CS Zinc Plated	CS Zinc Plated	CS Zinc Plated	CS Zinc Plated	Stainless Steel
Handle Grip*	Vinyl	Vinyl	Vinyl	Vinyl	Vinyl
Wrench Handle**	Ductile Iron	Ductile Iron	Ductile Iron	Ductile Iron	Ductile Iron
Wrench Head Bolt and Nut**	Alloy Steel	Alloy Steel	Alloy Steel	Alloy Steel	Alloy Steel
Stop Plate	Stainless Steel	Stainless Steel	Stainless Steel	Stainless Steel	Stainless Steel

\* 2" (50 mm) reduced port and smaller.

\*\* 2" (50 mm) full port and larger.

## DIMENSIONAL DATA – 4" REDUCED PORT AND SMALLER

### 1/4" Full Port through 4" Reduced Port: Flanged, Threaded and Socket Weld

B136/B138 Threaded

B100/B110 Class 150 Raised-face Flanges

B120/B128 Class 300 Raised-face Flanges

B114/B182 Class 600 Raised-face Flanges

B170/B172 Class 600 Ring joint Flanges

B106/B103 Socket Weld

#### 1" (25 mm) Reduced Port and Smaller

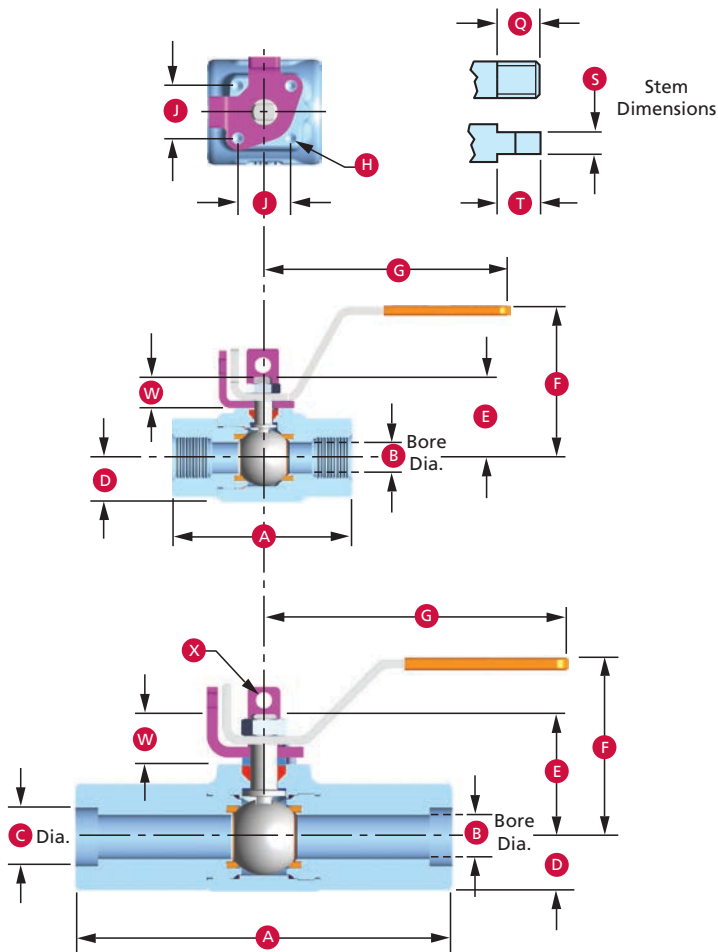

#### 1" (25 mm) Full Port through 2" (50 mm) Reduced Port

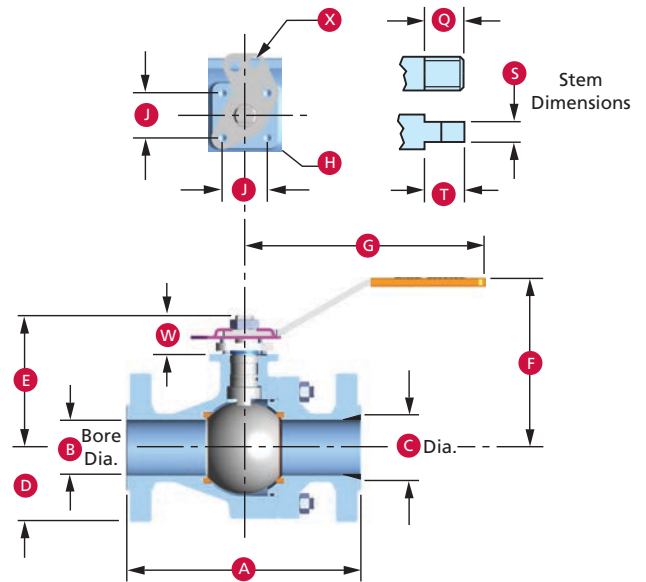

#### 2" (50 mm) Full Port through 4" (100 mm) Reduced Port

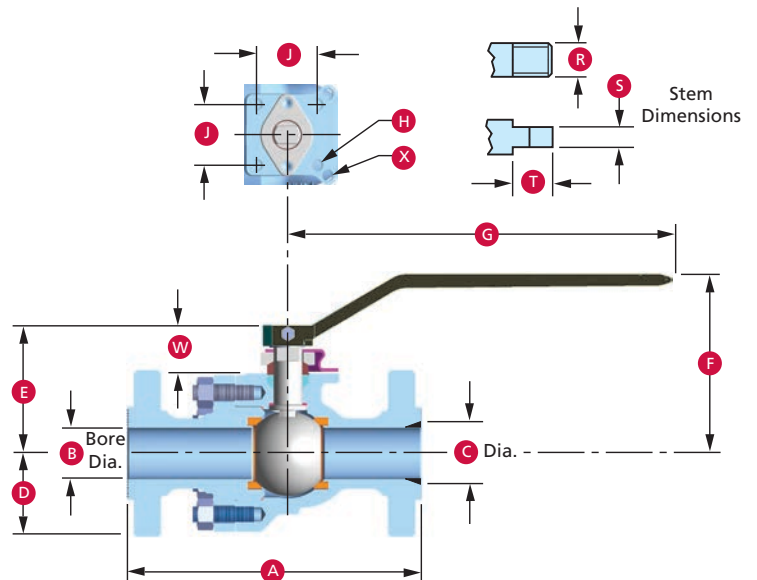



## Threaded and Flanged Ends

Size in.	A					B	C	D				E	F	G	H*	J	Q*	R	S	T	W	X
	THD	150	300	600	600RJ			THD	150	300	600											
1/4 FP	3.00	-	-	-	-	0.38	-	0.69	-	-	-	1.4	2.8	4.3	#8-32 .26 DP	0.88	5/16-24	-	0.18	0.25	0.55	0.38
3/8 FP	3.25	-	-	-	-	0.38	-	0.69	-	-	-	1.4	2.8	4.3	#8-32 .26 DP	0.88	5/16-24	-	0.18	0.25	0.55	0.38
1/2 RP	3.75	-	-	-	-	0.38	-	0.69	-	-	-	1.4	2.8	4.3	#8-32 .26 DP	0.88	5/16-24	-	0.18	0.25	0.55	0.38
1/2 FP	4.00	-	-	-	-	0.50	-	0.81	-	-	-	1.8	3.5	5.7	#10-24 .26 DP	1.00	7/16-20	-	0.26	0.34	0.72	0.38
3/4 FP	4.25	-	-	-	-	0.75	-	1.06	-	-	-	1.9	3.5	5.7	#10-24 .26 DP	1.00	7/16-20	-	0.26	0.34	0.72	0.38
1 RP	4.50	-	-	-	-	0.75	-	1.06	-	-	-	1.9	3.5	5.4	#10-24 .26 DP	1.00	7/16-20	-	0.26	0.34	0.72	0.38
1 FP	4.50	5.0	6.50	8.5	8.50	1.00	-	1.32	2.12	2.44	2.44	2.8	4.1	7.0	1/4-20 .39 DP	1.25	5/8-18	-	0.36	0.63	1.25	0.38
1-1/2 FP	5.25	6.5	7.50	9.5	9.50	1.50	-	1.81	2.50	3.06	3.06	3.7	5.0	9.5	5/16-18 .45 DP	1.50	3/4-16	-	0.45	0.81	1.50	0.38
2 RP	6.25	7.0	8.50	11.5	11.62	1.50	2.0	1.81	3.00	3.25	3.25	3.7	5.0	9.5	5/16-18 .45 DP	1.50	3/4-16	-	0.45	0.81	1.50	0.38
2 FP	6.25	7.0	8.50	11.5	11.62	2.00	-	2.38	3.00	3.25	3.25	5.0	5.4	15.0	1/2-13 .50 DP	2.44	-	1.12	0.69	1.37	1.88	0.38
3 x 2 RP	9.00	8.0	11.12	14.0	14.12	2.00	3.0	2.38	3.75	4.12	4.12	5.0	5.4	15.0	1/2-13 .50 DP	2.44	-	1.12	0.69	1.37	1.88	0.38
3 FP	10.00	8.0	11.12	14.0	14.12	3.00	-	3.28	3.75	4.12	4.12	6.4	7.1	15.0	1/2-13 .50 DP	3.00	-	1.12	0.74	1.75	2.31	0.38
4 RP	10.25	9.0	12.00	17.0	17.12	3.00	4.0	3.28	4.50	5.00	5.38	6.4	7.1	15.0	1/2-13 .50 DP	3.00	-	1.12	0.74	1.75	2.31	0.38
Size mm																						
6 FP	76	-	-	-	-	10	-	18	-	-	-	35	70	108	#8-32 6.6 DP	22	5/16-24	-	5	6	14	10
10 FP	83	-	-	-	-	10	-	18	-	-	-	35	70	108	#8-32 6.6 DP	22	5-16-24	-	5	6	14	10
15 RP	95	-	-	-	-	10	13	18	-	-	-	35	70	108	#8-32 6.6 DP	22	5/16-24	-	5	6	14	10
15 FP	102	-	-	-	-	13	-	20	-	-	-	45	89	145	#10-24 6.6 DP	25	7/16-20	-	7	9	18	10
20 FP	108	-	-	-	-	19	-	27	-	-	-	48	89	145	#10-24 6.6 DP	25	7/16-20	-	7	9	18	10
25 RP	114	-	-	-	-	19	25	27	-	-	-	48	89	137	#10-24 6.6 DP	25	7/16-20	-	7	9	18	10
25 FP	114	127	165	216	216	25	-	34	54	62	62	71	107	178	1/4-20 9.9 DP	32	5/8-18	-	9	16	31	10
40 FP	133	165	190	241	241	38	-	46	64	78	78	94	127	241	5/16-18 11.4 DP	38	3/4-16	-	11	21	38	10
50 RP	159	178	216	292	295	38	51	46	76	83	83	94	127	241	5/16-18 11.4 DP	38	3/4-16	-	11	21	38	10
50 FP	159	178	216	292	295	51	-	60	76	83	83	127	137	381	1/2-13 12.7 DP	62	-	28	18	35	48	10
80 x 50 RP	229	203	283	356	359	51	76	60	95	105	105	127	137	381	1/2-13 12.7 DP	62	-	28	18	35	48	10
80 FP	254	203	283	356	359	76	-	83	95	105	105	163	180	381	1/2-13 12.7 DP	76	-	28	19	44	59	10
100 RP	260	229	305	432	435	76	102	83	114	127	137	164	180	381	1/2-13 12.7 DP	76	-	28	19	44	59	10

## Socket Weld End

Size in.	A	B	C	D	E	F	G	H	J	Q*	S	T	W	X	
1/4 FP	B103	7.00	0.38	1.41	0.62	1.41	2.84	4.25	#8-32 .25 DP	0.88	5/16-24	0.18	0.25	0.56	0.38
3/4 FP	B103	8.25	0.75	1.94	1.00	1.94	3.75	5.75	#10-24 .25 DP	1.00	7/16-20	0.26	0.34	0.75	0.38
1 RP	B106	8.25	0.75	1.94	1.00	1.94	3.75	5.75	#10-24 .25 DP	1.00	7/16-20	0.26	0.34	1.14	0.38
1-1/2 FP	B103	9.25	1.50	3.56	1.75	3.56	5.00	9.50	5/16-18 .44 DP	1.50	3/4-16	0.45	0.81	1.34	0.38
2 RP	B106	10.25	1.50	3.56	1.75	3.56	5.00	9.50	5/16-18 .44 DP	1.50	3/4-16	0.45	0.81	1.34	0.38
Size mm															
8 FP	B103	177.80	9.65	35.81	15.75	35.81	72.14	107.95	#8-32 6.4 DP	22.35	5/16-24	4.57	6.35	14.22	9.65
20 FP	B103	209.55	19.05	49.28	25.40	49.28	95.25	146.05	#10-24 6.4 DP	25.40	7/16-20	6.60	8.64	19.05	9.65
25 RP	B106	209.55	19.05	49.28	25.40	49.28	95.25	146.05	#10-24 6.4 DP	25.40	7/16-20	6.60	8.64	28.96	9.65
40 FP	B103	234.95	38.10	90.42	44.45	90.42	127.00	241.30	5/16-18 11.2 DP	38.10	3/4-16	11.43	20.57	34.04	9.65
50 RP	B106	260.35	38.10	90.42	44.45	90.42	127.00	241.30	5/16-18 11.2 DP	38.10	3/4-16	11.43	20.57	34.04	9.65

\* American National Thread in inches.

## FEATURES AND BENEFITS

Handle can be installed in correct position only in alignment with the ball port. Handle aligned with piping shows valve is open. Handle perpendicular to piping shows valve is closed. 4" (100 mm) and 6" (150 mm) bore only.

310C ASME Classes 150 and 300

4" Full Port through 8" Reduced Port

NACE MR0175/ISO 15156

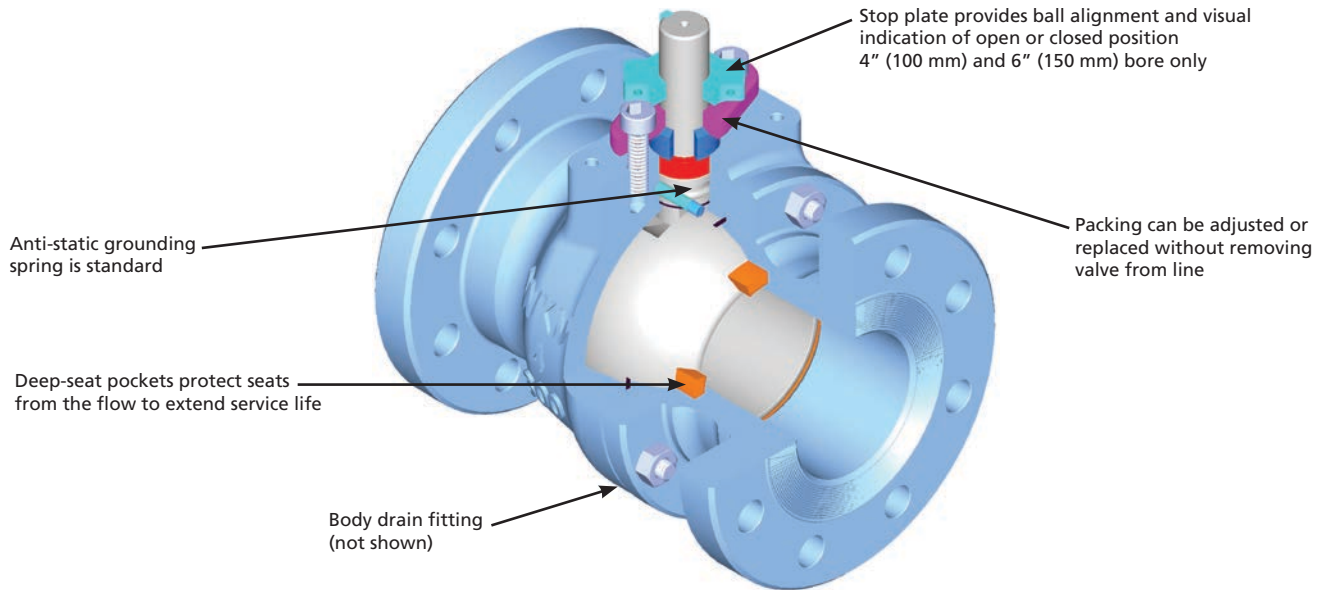

310F2 ASME Class 600

4" Full Port through 8" x 6" Reduced Port

NACE MR0175/ISO 1515

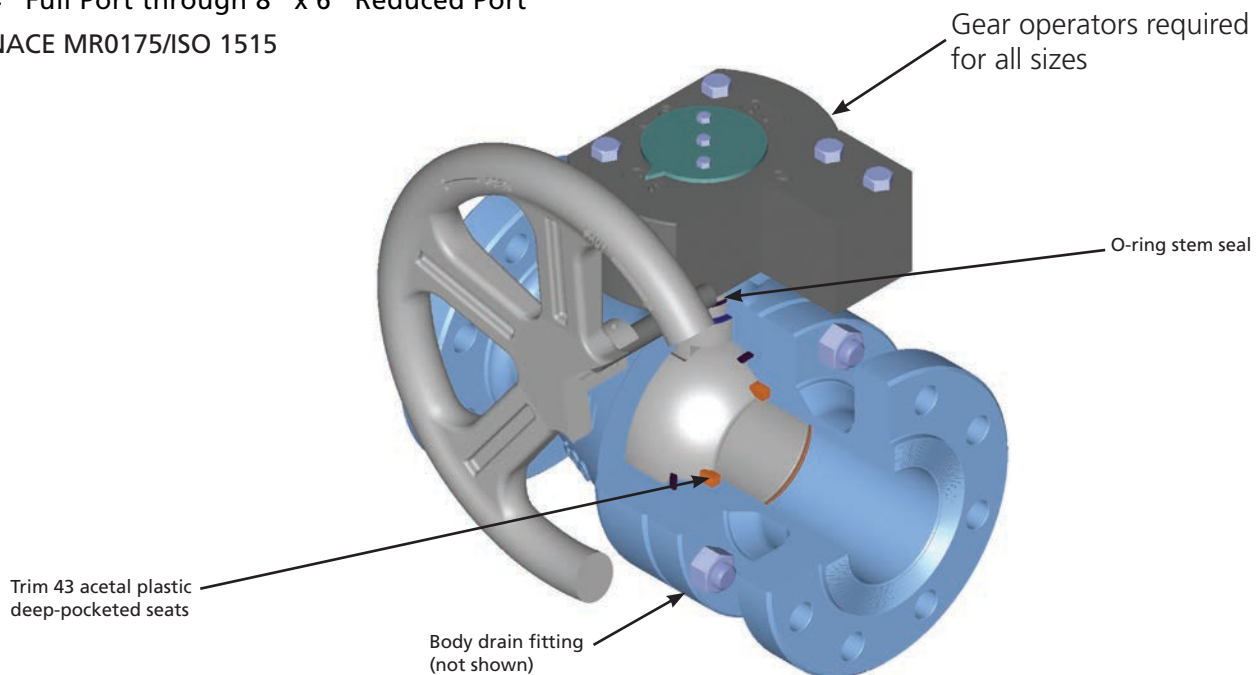

WKM DynaSeal 310 ball valves satisfy a wide range of applications. Available in a variety of standard and optional materials, they may be specified in sizes from 4" (100 mm) to 8" x 6" (200 mm x 150 mm) and ASME Class 150 and 300. ASME Class 600 is available in sizes 4" (100 mm) through 8" x 6" (200 mm x 150 mm). Engineered for heavy-duty, maintenance-free performance, the WKM DynaSeal 310 ball valve is commonly selected for a variety of applications in virtually any industry.

### **Chemical and Petrochemical Plants**

There is a wide range of chemical and petrochemical applications for WKM DynaSeal 310 ball valves. They are serving in many plastic plants, handling such slurries as 40% vinyl chloride in high-pressure catalyst lines; and in processes, handling dry lading such as polyethylene and polystyrene powders.

There are hundreds of applications in such plants where WKM DynaSeal 310 ball valves are providing efficient service.

### **Refining**

The WKM DynaSeal 310 ball valve is ideal for the refining industry. The many metal seats, seals and available trims offer the versatility needed to handle the wide variety of products used in the refining process.

### **High-temperature Service**

Special high-temperature trims are available for WKM DynaSeal 310 ball valves, which provide for service to 600° F (316° C). This trim is designed for steam service, hot oil, heat transfer fluids, boiler feed water and similar applications.

### **Low-temperature Service**

Standard trims accommodate temperatures to -20° F (-29° C). For temperatures to -50° F (-46° C), please consult factory.

### **Maintenance-free Performance**

Under most conditions, the WKM DynaSeal 310 ball valve will provide years of trouble-free service with no maintenance required.

In some severe applications, such as handling extremely abrasive slurries at high temperature, it may be necessary to replace the seats occasionally.

Seat and seal kits are available, and replacement can be done easily with ordinary tools.

### **Sour Oil and Gas Service**

WKM DynaSeal 310 ball valves have served for years in gathering lines, manifolds and field processing units in sour oil and gas fields. They can be trimmed to conform with NACE MR0175/ISO 15156.

### **Actuation-friendly**

A variety of actuator types can be installed easily, including pneumatic, hydraulic, diaphragm, vane, electromechanical and electrohydraulic.

### **Fire-tested for Safety**

All WKM DynaSeal 310 ball valves are qualified under API Standard 607. The pocketed seat and locked-in stem design contributes to its fire-tested characteristics. Should the soft seats be destroyed by fire, the ball floats down stream, providing a tight metal-to-metal seal against the lip of the seat pocket. If the tailpiece seals are destroyed, the metal-to-metal tailpiece-to-body connection retards external leakage.



WKM DynaSeal 310 ball valve with pneumatic actuator

## FEATURES AND BENEFITS (CONTINUED)

### Deep-recessed Seats

The seat is recessed into a deep machined pocket that surrounds and protects the seat on all sides. This design eliminates cold flow into the valve conduit, where it can be damaged by the action of the ball or the flow medium. The result is long and extended service life.

### Teflon Body Seal

A Teflon body seal is used between the valve body and tailpiece.

### Adjustable, Replaceable Packing

The in-line valve stem packing through ASME class 300 consists of PTFE impregnated graphite with a metal barrier. The packing is field-adjustable and virtually never requires lubrication. The packing and the stainless steel cap can be replaced without removing the valve from line.

### Fugitive Emissions

WKM DynaSeal 310 ball valves through ASME Class 300 can be supplied and certified to meet the requirements of fugitive emissions as regulated by The 1990 Amendment to The Clean Air Act to 100 ppm.

### Positively Retained Stem

The stem is positively retained and cannot be removed with the valve in service.

### Indicator Handle

The design of the handle ASME class 300 permits installation on the stem in the correct position only, in alignment with the ball port. When the handle is aligned with the pipe, the valve is open. When the handle is perpendicular to the pipe, the valve is closed.

### Floating Ball Design Delivers Tight Seal

The ground and polished ball is free to float and mates perfectly with the conical seats for a positive, leakproof seal. Self-cleaning and self-adjusting, the ball also is pressure activated – the higher the line pressure, the tighter the seal.

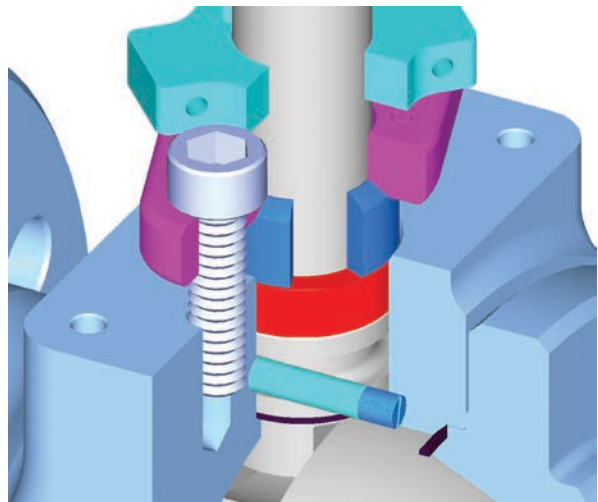
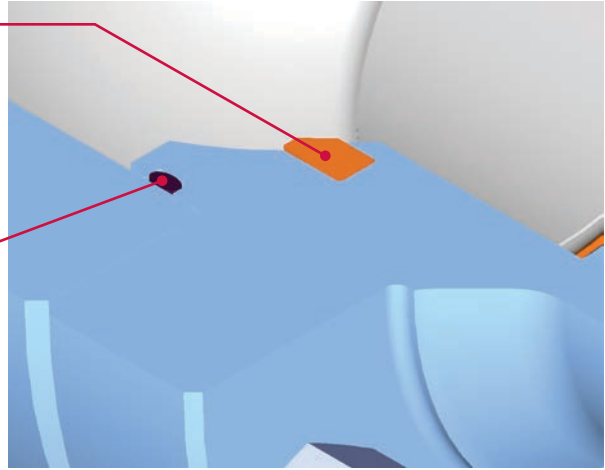

### Gear Mounting Brackets For:

4" FP to 8" RP  
(100 mm FP to 200 mm RP)  
ASME Classes 150/300

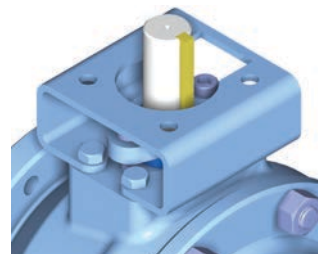

## SPECIFICATIONS

ASME Classes 150 and 300

### Operating Temperatures

- From -50° F to 600° F (-46° C to 316° C)

### Standard Material

#### Body

- Carbon steel and stainless steel

#### Ball/Stem

- Carbon steel and stainless steel

### Industry Compliance

- ASME B16.5, B16.34
- MSS-SP-25, 55, 72
- API 607 Fire-test Specification
- GOST-R

### ASME Pressure Class

Size			Class	
in.	(mm)		150	300
4	(100)	FP	•	•
6 x 4	(150 x 100)	RP	•	•
6	(150)	FP	•	•
8 x 6	(200 x 150)	RP	•	•

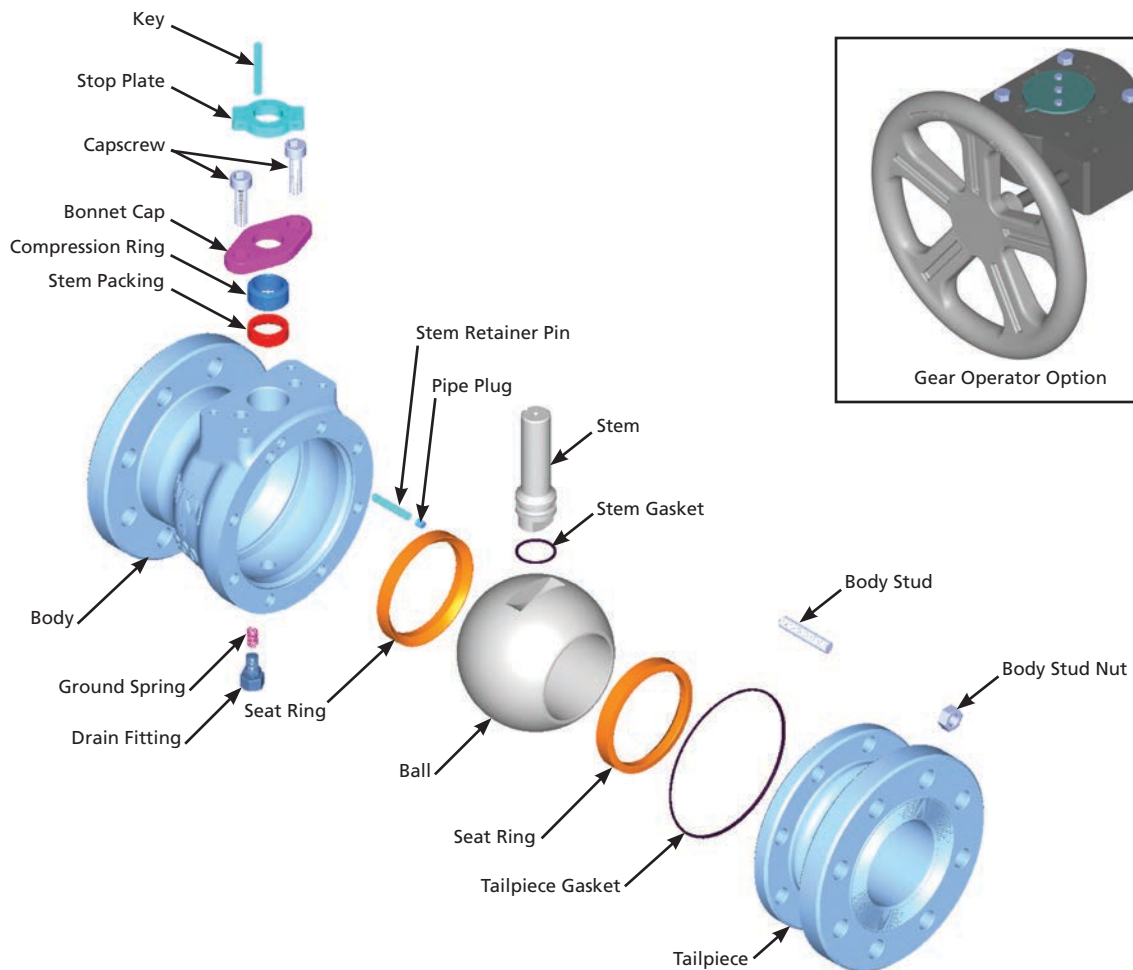



## SPECIFICATIONS

ASME Class 600

### Operating Temperatures

- From -20° F to 220° F (-29° C to 104° C)

### Standard Material

Body

- Carbon steel

Ball/Stem

- Carbon steel and stainless steel

### Industry Compliance

- ASME B16.5, B16.34
- MSS-SP-25, 55, 72
- API 607 Fire-test Specification
- GOST-R

### ASME Pressure Class

Size		Class
in.	(mm)	
4	(100)	FP •
6 x 4	(150 x 100)	RP •
6	(150)	FP •
8 x 6	(200 x 150)	RP •

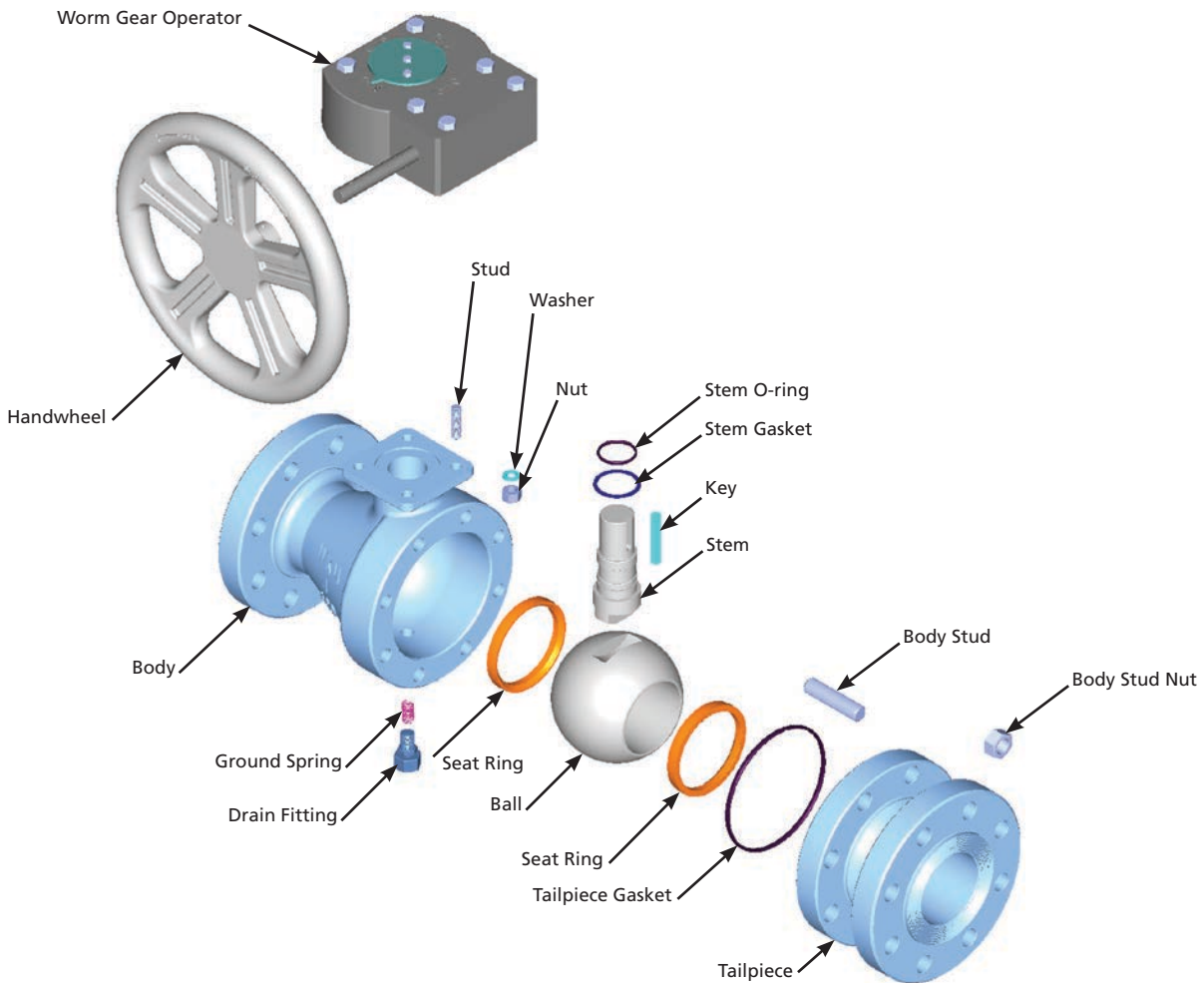

## MATERIALS LIST

### 4" Full Port through 8" Reduced Port

#### ASME Classes 150, 300 and 600

#### Body / Tailpiece Material Code

Part	CS	CS1*‡	CS2*	S1	S8*
Body	A216 Gr. WCC	A216 Gr. WCC	A216 Gr. WCC	A351 Gr. CF8M	A351 Gr. CF8M
Studs	A193 Gr. B7	A192 Gr. B7	A193 Gr. B7 †	A193 Gr. B7 Plated	A193 Gr. B8
Nuts	A194 Gr. 2H	A194 Gr. 2H	A194 Gr. 2H †	A194 Gr. 2H Plated	A194 Gr. B8
Body Drain Fitting	Carbon Steel	Carbon NACE	Stainless Steel	Stainless Steel	Stainless Steel
Tailpiece	ASTM A105/A216 Gr. WCC	ASTM A216 Gr. WCC	ASTM A105/A216 Gr. WCC	A351 Gr. CF8M	A351 CF8M
Packing Adjust Studs	A193 Gr. B7	N/A	A193 Gr. B7	A193 Gr. B7 Plated	A193 Gr. B8
Packing Adjust Nuts	A194 Gr. 2H	N/A	A194 Gr. 2H	A194 Gr. 2H Plated	A194 Gr. B8
Packing Adjusting Screws**	Alloy Steel	N/A	Alloy Steel	Alloy Steel Plated	Stainless Steel
Bonnet Cap	A216 Gr. WCC Plated	N/A	A216 Gr. WCC Plated	A216 Gr. WCC Plated	A351 Gr. CF8M

\* CS1, CS2 and S8 to be used for H<sub>2</sub>S service. Meets NACE MR0175/ISO 15156.

\*\* Use only for 4" (100 mm) through 8" x 6" (200 mm x 150 mm) ASME Classes 150 and 300.

† 4" (100 mm) through 8" x 6" (200 mm x 150 mm) ASME Class 600 uses A193 Gr. B7M studs and A194 Gr. 2HM nuts.

‡ Available in 4" (100 mm) through 8" x 6" (200 mm x 150 mm) ASME Class 600 only.

#### Seat / Seal Material Code

Part	01	42	43*	18	28	60S
Seat	TFE	Filled TFE	–	Special Filled TFE	Filled TFE	Nickel Alloy HVOF
Tailpiece Gasket	TFE	TFE	FKM O-ring	Filled TFE	Filled TFE	Graphite
Stem Gasket	TFE	Filled TFE	Nylon Washer	Filled TFE	Filled TFE	Graphite
Packing	Graphite/TFE with SS Cap		FKM O-ring**	Graphite/TFE with SS Cap		

\* Specify code 43 as standard trim for ASME class 600. Seal set consists of: acetal plastic seats, high-fluorine FKM O-ring for tailpiece and stem.

\*\* ASME Class 600 valves have FKM O-ring stem seal.

#### Ball / Stem Material Code

Part	CS	S1	S2*	60S
Ball	ASTM A105 Hard Chrome Plate	316 SS	316 SS	316 SS w/QPQ Nitride
Grounding Spring	304 SS	304 SS	304 SS	304 SS
Stem	Carbon Steel ENP	316 SS	Type 630	Type 630
Compression Ring	304 SS	304 SS	304 SS	304 SS
Stem Retainer Pin	Carbon Steel	316 SS	316 SS	304 SS
Stem Retainer Pipe Plug	Carbon Steel	316 SS	316 SS	304 SS

#### Actuator Codes\*

Part (Body)	Worm Gear – For All Body Material Codes
Mounting Bracket	Carbon Steel
Bolting	Carbon Steel
Set Screw	Carbon Steel
Stem Adapter	Carbon Steel
Actuator	As Selected
Handwheel	Carbon Steel

\* 4" (100 mm) through 8" (200 mm) ASME Class 600 sold with worm gear option only.

#### Actuator Codes (Wrenches)\*\*

Part (Body)	Wrench – For All Body Material Codes
Wrench Head	Steel
Wrench Handle	Carbon Steel
Wrench Handle Pin	Carbon Steel
Capscrew	Alloy Steel
Stop Plate	Carbon Steel

\*\* 4" (100 mm) through 8" x 6" (200 mm x 150 mm) ASME Class 150 and 300.

## DIMENSIONAL DATA – 4" FULL PORT AND LARGER

### 4" Full Port through 8" Reduced Port

ASME Classes 150, 300 and 600

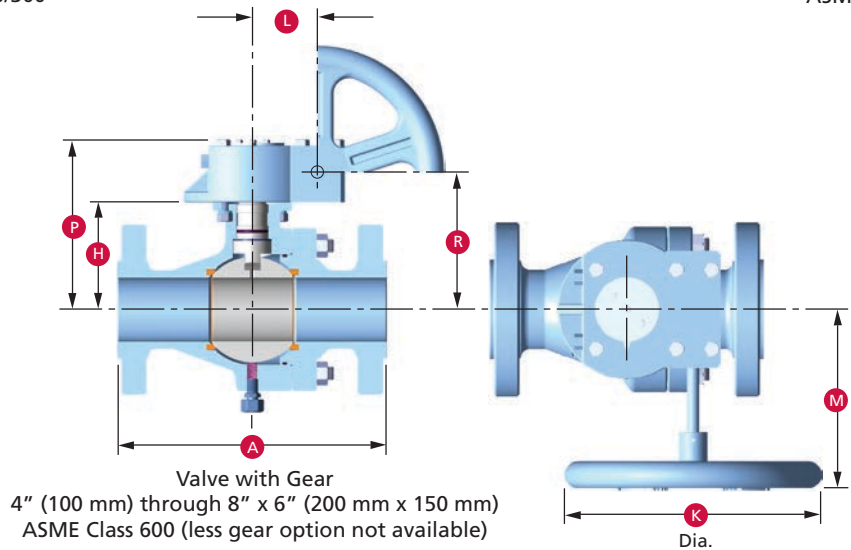
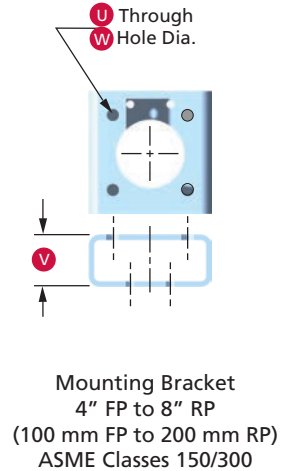
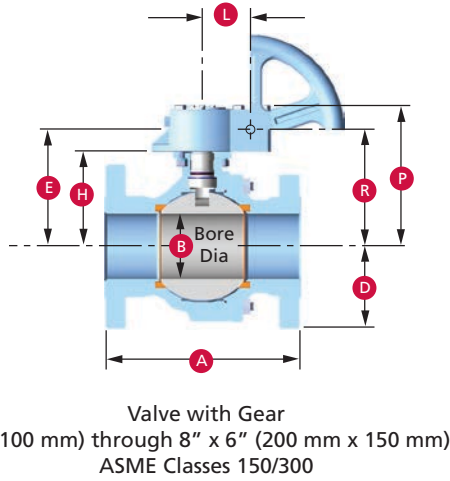
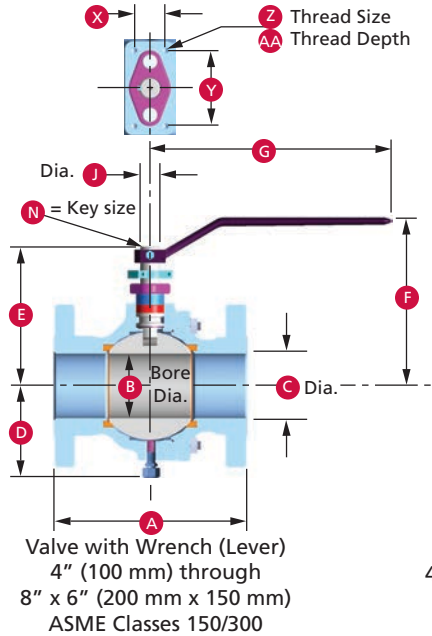

### ASME Class 600

#### Full Port Dimensions

Size	in.	A	B	C	D	H	K	L	M	P	R
4		17.00	4.00	4.00	6.52	6.81	16.00	2.50	9.72	9.79	8.18
6		22.00	6.00	6.00	8.17	9.28	20.00	4.84	14.26	13.43	11.25
Size	mm										
100		432	102	102	166	173	508	64	247	249	208
150		559	152	152	208	236	610	123	362	341	286

#### Reduced Port Dimensions

Size	in.	A	B	C	D	H	K	L	M	P	R
6 x 4		22.00	4.00	6.00	6.52	6.81	16.00	2.50	9.72	9.79	8.18
8 x 6		26.00	6.00	8.00	8.17	9.28	20.00	4.84	14.26	13.43	11.25
Size	mm										
150 x 100		559	102	152	166	173	508	64	247	249	208
200 x 150		660	152	203	208	236	610	123	362	341	286

### Full Port Dimensions

Size in.	A* Class					B	C	D	E	F	G	H	J	K	L	M	N	P	R	U	V	W	X	Y	Z	AA
	150 RF		300 RF		300																					
	Long	Short	Long	Short	BW																					
B110	B113	B128	B134	B150																						
4	9.00	N/A	–	N/A	–	4.0	4.0	6.47	8.63	9.88	36.0	7.56	1.250	6.0	2.80	7.88	0.250	10.84	9.15	0.56	2.44	4.921	1.88	4.63	3/8-16NC	0.63
	–		12.00		–	12.00	4.0	4.0	6.47	8.63	9.88	36.0	7.56	1.250	6.0	2.80	8.12	0.250	10.84	9.15	0.56	2.44	4.921	1.88	4.63	3/8-16NC
6	15.50	10.50	–	N/A	–	6.0	6.0	8.20	11.38	12.63	48.0	9.44	1.500	12.0	2.80	10.95	0.375	12.72	11.03	0.56	2.44	4.921	1.88	4.63	3/8-16NC	0.63
	–	–	15.88		15.88	6.0	6.0	8.20	11.38	12.63	48.0	9.44	1.500	14.0	4.11	13.24	0.375	13.28	11.33	0.56	2.44	4.921	1.88	4.63	3/8-16NC	0.63

### mm

Size	A* Class					B	C	D	E	F	G	H	J	K	L	M	N	P	R	U	V	W	X	Y	Z	AA
	150 RF		300 RF		300																					
	Long	Short	Long	Short	BW																					
B110	B113	B128	B134	B150																						
100	229	N/A	–	N/A	–	102	102	164	219	251	914	192	31.75	150	71	200	6.35	275	232	14	62	124.99	48	118	3/8-16NC	16
	–		305		–	305	102	102	164	219	251	914	192	31.75	150	71	206	6.35	275	232	14	62	124.99	48	118	3/8-16NC
150	394	267	–	N/A	–	152	152	208	289	321	1219	240	38.1	356	71	278	9.53	323	280	14	62	124.99	48	118	3/8-16NC	16
	–	–	403		403	152	152	208	289	321	1219	240	38.1	300	104	336	9.53	337	280	14	62	124.99	48	118	3/8-16NC	16

### Reduced Port Dimensions

Size in.	A* Class				B	C	D	E	F	G	H	J	K	L	M	N	P	R	U	V	W	X	Y	Z	AA	
	150 RF		300 RF																							
	Long	Short	Long	Short																						
B100	B102	B120	B122																							
6 x 4	N/A	10.5	–	N/A	4.0	6.0	6.45	8.63	9.88	36.0	7.56	1.25	6.0	2.8	7.88	0.25	10.84	9.15	0.56	2.44	4.921	1.88	4.63	3/8-16NC	0.63	
		–	15.88		–	4.0	6.0	6.45	8.63	9.88	36.0	7.56	1.25	6.0	2.8	8.12	0.25	10.84	9.15	0.56	2.44	4.921	1.88	4.63	3/8-16NC	0.63
8 x 6	18.0	11.5	–	N/A	–	6.0	8.0	8.2	11.38	12.63	48.0	9.44	1.5	14.0	2.8	10.95	0.375	12.72	11.03	0.56	2.44	4.921	1.88	4.63	3/8-16NC	0.63
	–	–	16.50		–	6.0	8.0	8.2	11.38	12.63	48.0	9.44	1.5	16.0	4.11	11.11	0.375	13.28	11.33	0.56	2.44	4.921	1.88	4.63	3/8-16NC	0.63

### mm

Size	A* Class				B	C	D	E	F	G	H	J	K	L	M	N	P	R	U	V	W	X	Y	Z	AA	
	150 RF		300 RF																							
	Long	Short	Long	Short																						
B100	B102	B120	B122																							
150 x 100	N/A	267	–	N/A	102	152	164	219	251	914	192	31.75	150	71	200	6.35	275	232	14	62	124.99	48	118	3/8-16NC	16	
		–	403		–	102	152	164	219	251	914	192	31.75	150	71	206	6.35	275	232	14	62	124.99	48	118	3/8-16NC	16
200 x 150	457	292	–	N/A	–	152	203	208	289	321	1219	240	38.1	356	71	278	9.53	323	280	14	62	124.99	48	118	3/8-16NC	16
	–	–	419		–	152	203	208	289	321	1219	240	38.1	406	104	282	9.53	337	288	14	62	124.99	48	118	3/8-16NC	16

\* Center line-to-face dimension is half of dimension A, except:  
 4" (100 mm) ASME class 150 Full Port – stem is offset 1/2" (12.7 mm) towards body end and 6" (150 mm).  
 ASME class 150 Full Port Long Pattern – stem is offset 2-1/2" (63.5 mm) towards body end.

## PRESSURE/TEMPERATURE FOR ALL DYNASEAL 310 FLOATING BALL VALVES

WKM DynaSeal 310 ball valves are rated for high performance and long life. The ratings shown here are based on tests that indicate good seat performance and acceptable wear. This rating is determined by the lower of the valve's pressure or seat rating. The seat rating is the maximum differential pressure to which the valve should be subjected on a continuous basis. Seal codes 01, 42 and 07 are suitable for vacuum service to 20 microns, absolute (minimum temperature 0° F (-18° C)).

### Seal Code 01

Temp		Valve Port Size in. (mm)				
° F	° C	1/4 to 3/4 (80 to 20)	1 to 1-1/2 (25 to 40)	2 (50)	3 to 4 (80 to 100)	6 to 12 (150 to 300)
-50 to 100	-46 to 38	1500	1000	750	600	285
200	93	1500	1000	750	600	285
250	121	1400	900	700	550	150
300	149	1100	650	500	425	50
350	177	600	375	300	250	–
400	204	100	100	100	100	–

### Seal Codes 42 and 28

Temp		Valve Port Size in. (mm)	
° F	° C	4 (100)	6 (150)
-50 to 100	-46 to 38	740	740
250	121	740	675
300	149	740	550
350	177	590	410
400	204	400	300
450	232	325	175
500	260	200	65

### Seal Code 42

Temp		Valve Port Size in. (mm)		
° F	° C	1/4 to 1-1/2 (8 to 40)	2 (50)	3 (80)
-50 to 100	-46 to 38	1500	1500	740
200	93	1400	1325	740
250	121	1250	1150	740
300	149	1090	975	740
350	177	930	800	590
400	204	770	640	450
450	232	610	475	325
500	260	450	300	200

### Seal Code 18

Temp		Valve Port Size in. (mm)			
° F	° C	1/4 to 1-1/2 (8 to 40)	2 (50)	3 (80)	4 to 6 (100 to 150)
-50 to 100	-46 to 38	*	*	*	*
200	93	*	*	*	*
250	121	1775	1250	*	*
300	149	1650	1175	740	600
350	177	1575	1075	700	500
400	204	1500	1000	650	400
450	232	1300	875	600	300
500	260	1075	725	550	200
550	288	850	600	500	100
600	316	350	100	75	0
625	329	100	0	0	0

### Seal Codes 43 and 48

Temp		Valve Port Size in. (mm)				
° F	° C	1/4 to 1-1/2 (8 to 40)	2 (50)	3 (80)	4 (100)	6 (150)
-50 to 100	-46 to 38	3000	3000	1500	1500	1500
200	93	3000	3000	1500	1500	1500
220	104	3000	3000	1375	1375	1375

\* On application.

### Seal Code 23

Temp		Valve Port Size in. (mm)	
° F	° C	1/4 to 3/8 (8 to 10)	1/2 to 3/4 (15 to 20)
-50 to 100	-46 to 38	5000	3750
200	93	3250	2000
225	107	2500	1500

### Seal Code 07\*

Temp		Valve Port Size in. (mm)		
° F	° C	1/4 to 1-1/2 (8 to 40)	2 (50)	3 (80)
-20 to 100	-29 to 38	740*	500*	285*
350	177	500	350	200
400	204	250	190	100

### Seal Code 60S and 92H

Follows B16.34 rating for body material shown on pages 27 and 28.

\* Block-and-bleed range.



## BODY ASSEMBLIES

### Flanged Valves

Data are maximum working pressure ratings for the valve body assembly at various temperatures. Practical pressure limitations according to actual service conditions are determined by the seal and tailpiece gasket materials. These pressure/temperature ratings are in conformance with ASME B16.5 and B16.34.

#### Maximum Working Pressures – psig

Temp ° F Valve Class	Body Material Codes					
	CS, CS2 and CS3			S1 and S8		
	150	300	600	150	300	600
-20 to 100	285	740	1480	275	720	1440
150	272	707	1415	255	670	1340
200	260	675	1350	235	620	1240
250	245	665	1332	225	590	1180
300	230	655	1315	215	560	1120
350	215	645	1292	205	537	1073
400	200	635	1270	195	515	1025
450	185	617	1235	182	497	990
500	170	600	1200	170	480	955
550	155	575	1147	155	465	928
600	140	550	1095	140	450	900

#### Maximum Working Pressures – bars (1 bar = 14.5 psi)

Temp ° C Valve Class	Body Material Codes					
	CS, CS2 and CS3			S1 and S8		
	20PN	50PN	100PN	20PN	50PN	100PN
-29 to 38	20	51	102	19	50	100
66	19	49	98	18	46	92
93	18	47	93	16	43	85
121	17	46	92	16	41	81
149	16	45	91	15	39	77
177	15	44	89	14	37	74
204	14	44	88	13	36	71
232	13	43	85	13	34	68
260	12	41	83	12	33	66
288	11	40	79	11	32	64
316	10	38	75	10	31	62

## BODY ASSEMBLIES (CONTINUED)

### Threaded Valves

Body Trim Code S8 and CS3 are suitable for service to -50° F (-46° C). All other trims are limited to operating temperatures no lower than -20° F (-29° C). These pressure/temperature ratings are in conformance with ASME B16.5, B16.34.

#### Maximum Working Pressures – psig

Temp ° F	Body Material Codes										
	Valve Bore Size in.	CS, CS2 and CS3					S1 and S8				
		1/4 to 3/8	1/2 to 3/4	1 to 1-1/2	2	3	1/4 to 3/8	1/2 to 3/4	1 to 1-1/2	2	3
-20 to 100	5000	3750	3000	2000	1500	5000	3750	3000	2000	1500	
150	4779	3583	2867	1912	1434	4650	3487	2790	1861	1396	
200	4557	3416	2734	1824	1368	4301	3224	2580	1722	1292	
250	4494	3368	2696	1800	1350	4092	3068	2455	1639	1229	
300	4431	3320	2658	1775	1333	3884	2912	2330	1556	1167	
350	4355	3264	2613	1744	1310	3725	2794	2236	1491	1117	
400	4278	3209	2567	1713	1287	3566	2677	2141	1426	1068	
450	4161	3120	2496	1665	1252	3442	2583	2066	1377	1031	
500	4043	3031	2425	1618	1216	3317	2489	1992	1328	995	
550	3868	2900	2320	1548	1163	3225	2419	1936	1291	966	
600	3694	2768	2215	1478	1110	3134	2349	1880	1254	938	

#### Maximum Working Pressures – bars (1 bar = 14.5 psi)

Temp ° C	Body Material Codes										
	Valve Bore Size mm	CS, CS2 and CS3					S1 and S8				
		8 to 10	15 to 20	25 to 40	50	80	8 to 10	15 to 20	25 to 40	50	80
-29 to 38	345	259	207	138	103	345	259	207	138	103	
66	330	247	198	132	99	321	240	192	128	96	
93	314	236	189	126	94	297	222	178	119	89	
121	310	232	186	124	93	282	212	169	113	85	
149	306	229	183	122	92	268	201	161	107	80	
177	300	225	180	120	90	257	193	154	103	77	
204	295	221	177	118	89	246	185	148	98	74	
232	287	215	172	115	86	237	178	143	95	71	
260	279	209	167	112	84	229	172	137	92	69	
288	267	200	160	107	80	222	167	134	89	67	
316	255	191	153	102	77	216	162	130	86	65	

## WEIGHTS

Valve Size		End Connection	Full Port Weight		Reduced Port Weight	
in.	(mm)		lb	kg	lb	kg
1/4	(6)	Threaded	1.50	0.68	–	–
3/8	(10)	Threaded	1.50	0.68	–	–
1/2	(15)	Threaded	1.50	0.68	1.50	0.68
3/4	(20)	Threaded	3.25	1.47	–	–
		Threaded	5.00	2.30	3.00	1.36
		150 (20 PN) Flanged	8.50	3.86	6.3	2.86
		300 (50 PN) Flanged	12.00	5.44	–	–
1	(25)	600 (100 PN) Flanged	32.00	14.50	–	–
		Threaded	12.00	5.44	–	–
		150 (20 PN) Flanged	17.00	7.71	–	–
		300 (50 PN) Flanged	24.00	10.90	–	–
1-1/2	(40)	600 (100 PN) Flanged	32.00	14.50	–	–
		Threaded	23.00	10.40	12.50	5.67
		150 (20 PN) Flanged	33.00	15.00	23.00	10.40
		300 (50 PN) Flanged	38.00	17.20	25.00	11.30
2	(50)	600 (100 PN) Flanged	47.00	21.30	33.00	15.00
		Threaded	56.00	25.40	36.00	16.30
		150 (20 PN) Flanged	64.00	29.00	51.00	23.10
		300 (50 PN) Flanged	81.00	36.70	76.00	35.00
3	(80)	600 (100 PN) Flanged	87.00	39.50	81.00	36.70
		Threaded	–	–	67.00	30.40
		150 (20 PN) Flanged	–	–	80.00	36.30
		300 (50 PN) Flanged	–	–	127.00	57.60
4	(100)	600 (100 PN) Flanged	–	–	130.00	59.00

Valve Size		End Connection	Full Port Weight		Reduced Port Weight	
in.	(mm)		lb	kg	lb	kg
4	(100)	150 (L) Flanged	113	51	–	–
		WGA	144	65	–	–
		600 Flanged	257	117	–	–
6	(150)	150 (L) Flanged	162	73	–	–
		150 (S) Flanged	144	65	125	57
		300 (L) Flanged	273	124	193	88
6	(150)	150 (L) Flanged	176	80	–	–
		WGA	158	72	133	60
		300 (L) Flanged	313	142	223	101
8	(200)	600 Flanged	545	247	363	165
		150 (L) Flanged	–	–	217	98
		150 (S) Flanged	–	–	197	89
		300 (S) Flanged	–	–	293	133

(S) Short pattern.  
(L) Long pattern.

## WEIGHTS (CONTINUED)

Valve Size		MOP	Male x Female Threaded Ends			
in.	(mm)		Full Port Weights		Reduced Port Weights	
			lb	kg	lb	kg
1/2	(15)	3000	–	–	3	1.36
1/2	(15)	5000	–	–	3	1.36
3/4	(20)	3000	6	2.72	–	–
3/4	(20)	3750	6	2.72	–	–
1	(25)	3000	–	–	7	3.18
1	(25)	3750	–	–	7	3.18
Socket Weld Ends						
1/4	(8)	3000	2	0.91	–	–
3/4	(20)	3000	6	2.72	–	–
1	(25)	3000	–	–	6	2.72
1-1/2	(40)	3000	19	8.62	–	–
2	(50)	3000	–	–	21	9.53

## FLOW CHARACTERISTICS ( $C_v$ )\*

Valve Size and Port Size		Threaded End Valves	Valve Pressure Class		
in.	(mm)		150	300	600
1/4 x 1/4	(8 x 8)	9	–	–	–
3/8 x 3/8	(10 x 10)	9	–	–	–
1/2 x 3/8	(15 x 10)	5	–	–	–
1/2 x 1/2	(15 x 15)	16	16	14	–
3/4 x 1/2	(20 x 15)	–	10	10	–
3/4 x 3/4	(20 x 20)	45	–	–	–
1 x 3/4	(25 x 20)	20	35	34	–
1 x 1	(25 x 25)	93	88	77	68
1-1/2 x 1-1/2	(40 x 40)	248	223	208	184
2 x 1-1/2	(50 x 40)	80	102	101	99
2 x 2	(50 x 50)	491	464	421	362
3 x 2	(80 x 50)	107	117	133	133
3 x 3	(80 x 80)	1099	1228	1042	928
4 x 3	(100 x 80)	322	359	410	406
4 x 4	(100 x 100)	–	2118	2446	–
6 x 4	(150 x 100)	–	390	391 (S)	–
6 x 6	(150 x 150)	–	5403	6644 (S) / 5468 (L)	–
8 x 6	(200 x 150)	–	1215	1219 (S) / 1215 (L)	–

\* Flow of water in US gallons per minute per 1 psi pressure drop across a fully open valve.  
(S) Short pattern.  
(L) Long pattern.

## STEM TORQUES (in-lb)

### Seat Seal Code 01

Valve Bore Size		Differential Pressure				
in.	(mm)	0 to 285	500	740	1000	1500
1/4 to 3/8	(8 to 10)	36	36	36	36	42
1/2	(15)	60	60	60	72	72
3/4	(20)	90	90	90	120	180
1	(25)	120	150	180	225	–
1-1/2	(40)	240	330	420	520	–
2	(50)	500	640	810	–	–
3	(80)	1200	1800	2400	–	–

### Seat Seal Code 42\*\*

Valve Bore Size		Differential Pressure				
in.	(mm)	0 to 285	500	740	1000	1500
1/4 to 3/8	(8 to 10)	36	36	36	36	42
1/2	(15)	60	60	60	72	72
3/4	(20)	90	90	90	120	180
1	(25)	120	150	180	225	300
1-1/2	(40)	240	330	420	520	720
2	(50)	500	640	810	1090	1440
3	(80)	1200	1800	2400	–	–

\*\* Multiply trim 42 torque by two for seat seal code 60S and 92H.

### Seat Seal Codes 43 and 48

Valve Bore Size		Differential Pressure									
in.	(mm)	0 to 285	500	740	1000	1500	2000	2250	2500	3000	
1/4 to 3/8	(8 to 10)	48	48	48	50	55	60	70	85	100	
1/2	(15)	58	60	64	70	90	120	140	165	215	
3/4	(20)	90	95	105	125	175	230	260	295	370	
1	(25)	225	245	260	280	320	400	455	520	700	
1-1/2	(40)	390	410	450	510	700	920	1050	1200	1550	
2	(50)	860	960	1075	1210	1500	1830	2000	2200	2600	
3	(80)	1450	1635	1885	2220	3050	–	–	–	–	

### Seat Seal Code 18

Valve Bore Size		Differential Pressure					
in.	(mm)	0 to 285	500	740	1000	1500	2250
1/4 to 3/8	(8 to 10)	60	60	60	60	72	84
1/2	(15)	60	60	60	70	84	108
3/4	(20)	128	128	145	160	215	360
1	(25)	274	284	312	360	405	580
1-1/2	(40)	520	580	680	810	980	1390
2	(50)	910	1042	1240	1500	1765	2300
3	(80)	1200	1800	2400	2900	3420	–

### Seat Seal Code 07

Valve Bore Size		Liquid	Dry Gas	
in.	(mm)	0 to 285	0 to 285	740
1/4 to 3/8	(8 to 10)	36	42	113
1/2	(15)	60	82	220
3/4	(20)	90	150	404
1	(25)	180	336	606
1-1/2	(40)	420	840	2260
2	(50)	900	1200	3230
3	(80)	2400	3600	9690

## STEM TORQUES (in-lb) (CONTINUED)

### Seat Seal Code 23

Valve Bore Size		Differential Pressure													
in.	(mm)	0 to 285	500	740	1000	1500	2000	2250	2500	3000	3500	3750	4000	4500	5000
1/4 to 3/8	(8 to 10)	60	60	60	60	60	65	70	85	100	115	125	130	150	165
1/2	(15)	70	70	70	82	110	125	140	180	220	276	310	-	-	-
3/4	(20)	108	108	125	140	190	260	340	420	560	695	800	-	-	-

### Seat Seal Code 01

Valve Bore Size		Differential Pressure		
in.	(mm)	0 to 285	500	740
4	(100)	2090	3300	4200
6	(150)	4400	8200	11,200

### Seat Seal Codes 28 and 42

Valve Bore Size		Differential Pressure		
in.	(mm)	0 to 285	500	740
4	(100)	2400	3300	4200
6	(150)	5400	8200	11,200

NOTE: The torque values listed for 285 psi and greater are based on valves controlling the flow of clean lubricating liquid at ambient temperature.

For valves at pressures less than 285 psi, use the value for 285 psi.

Interpolation may be used for any pressure above 285 psi, but less than maximum pressure listed.

Running torque values will average two-thirds of these values.

For running torque values less than breakaway torque values at 285 psi, use breakaway torque values.

Re-seating torque is equal to breakaway torque.

For operating temperatures between -20° F and -50° F (-29° C and -46° C), multiply these values by 1.20.

These torque values do not contain service or safety factors.

Actuator selection should be made based on experience and appropriate service and safety factors.



# WKM DynaSeal 210 and 310 Floating Ball Valves

## MATERIAL SELECTION GUIDE

A selection of body, stem and seat/seal materials for WKM DynaSeal valves are available. The following list is intended as a guide in the selection of materials for corrosive service. No material can be expected to resist the corrosive action of all the many ladings found in modern industry. Experience has shown, however, that certain materials can perform satisfactorily within certain limits. The physical properties of a material are affected differently by each corrosive medium. Therefore, it sometimes becomes necessary to sacrifice value in another property. As a result, the user must decide which property is of prime importance for his application. Internal moving parts, in contact with the lading, should always carry an "A" rating. Body materials with exposure to corrosive ladings can sometimes carry a "B" rating because metal loss due to corrosive is not as critical.

The following information is designed for use by technically qualified individuals at their own discretion and risk. We strongly recommend that tests be run under actual operating conditions to obtain a material's performance ability in any one corrosive medium.

### Rating Interpretation:

- "A" – Excellent
- "B" – Good (slightly attacked)
- "C" – Fair (moderately attacked)
- "D" – Not recommended

Lading	STD	STD	STD	STD	SPL	SPL	STD	SPL	SPL	STD	STD	STD	SPL	SPL
	BDY	BDY	BDY	BDY	BDY		42	18	07	43	INT	INT	INT	INT
	CS	S1	CS2	S8	CS3	01					CS	S1	S2	ML
ACETALDEHYDE	C	A	C	A	C	A	A	A	D	B	C	A	C	A
ACETATE SOLVENTS	A	A	A	A	A	A	A	A	D	B	A	A	A	A
ACETIC ACID (30%)	C	A	C	A	C	A	A	A	B	D	C	A	C	A
ACETIC ACID (AERATED)	D	A	D	A	D	A	A	A	D	D	D	A	D	A
ACETIC ACID (AIR-FREE)	D	A	D	A	D	A	A	A	D	D	D	B	D	A
ACETIC ACID (CRUDE)	C	A	C	A	C	A	A	A	D	D	C	A	C	A
ACETIC ANHYDRIDE	D	B	D	B	D	A	A	A	D	D	D	B	D	A
ACETONE	A	A	A	A	A	A	A	A	D	B	A	A	A	A
ACETYLENE (DRY ONLY)	A	A	A	A	A	A	A	A	A	D	A	A	A	A
ACRYLONITRILE	A	A	A	A	A	A	A	A	C	C	A	A	A	A
ALCOHOL-AMYL	B	A	B	A	B	A	A	A	B	B	B	A	B	A
ALCOHOL-BUTYL	B	A	B	A	B	A	A	A	A	C	B	A	B	A
ALCOHOL-ETHYL	B	A	B	A	B	A	A	A	C	B	B	A	B	A
ALCOHOL-METHYL (METHANOL)	B	A	B	A	B	A	A	A	D	C	B	A	B	A
ALUMINUM CHLORIDE (DRY)	B	A	B	A	B	A	A	A	A	D	B	A	B	A
ALUMINUM SULFATE (ALUMS)	C	A	C	A	C	A	A	A	A	B	C	A	C	A
ALUMS	C	A	C	A	C	A	A	A	A	C	C	A	C	A
AMINES	A	A	A	A	A	A	A	A	B	C	A	A	A	A
AMINES-BASED CORROSION INHIBITOR	A	A	A	A	A	A	A	A	-	B	A	A	A	A
AMINES RICH	D	A	A	A	A	A	A	A	-	C	D	A	A	A
AMMONIA (AQUEOUS)	A	A	A	A	A	A	A	A	D	D	A	A	A	B
AMMONIA ANHYDROUS	A	A	A	A	A	A	A	A	D	D	A	A	A	B
AMMONIA SOLUTIONS	B	A	B	A	B	A	A	A	D	D	B	A	B	B
AMMONIUM BICARBONATE	C	B	C	B	C	A	A	A	B	D	C	B	C	B
AMMONIUM CARBONATE	B	B	B	B	B	A	A	A	B	D	B	B	B	B
AMMONIUM CHLORIDE	D	C	D	C	D	A	A	A	A	B	D	C	D	B
AMMONIUM HYDROXIDE (28%)	C	B	C	B	C	A	C	C	B	C	C	B	C	D
AMMONIUM HYDROXIDE CONCENTRATED	C	B	C	B	C	A	C	C	D	D	C	B	C	D
AMMONIUM MONOPHOSPHATE	D	B	D	B	D	A	A	A	B	B	D	B	D	C
AMMONIUM NITRATE	D	A	D	A	D	A	A	A	C	C	D	A	D	D
AMMONIUM PHOSPHATE (DIBASIC)	D	B	D	B	D	A	A	A	A	C	D	B	D	C
AMMONIUM PHOSPHATE (TRIBASIC)	D	B	D	B	D	A	A	A	A	C	D	B	D	C
AMMONIUM SULFATE	C	B	C	B	C	A	A	A	A	A	C	B	C	C
AMYL ACETATE	C	B	C	B	C	A	A	A	D	B	C	B	C	B
ANILINE	A	B	A	B	A	A	A	A	C	C	A	B	A	B
ANILINE DYES	C	A	C	A	C	A	A	A	B	C	C	A	C	A
ANTIMONY TRICHLORIDE	D	D	D	D	D	A	A	A	A	D	D	D	D	B
APPLE JUICE	D	B	D	B	D	A	A	A	A	A	D	B	D	A
ARSENIC ACID	D	B	D	B	D	A	A	A	A	A	D	B	D	D
ASPHALT EMULSION	A	A	A	A	A	A	A	A	A	B	A	A	A	A
ASPHALT LIQUID	A	A	A	A	A	A	A	A	A	B	A	A	A	A
BARIUM CARBONATE	B	B	B	B	B	A	A	A	A	A	B	B	B	B
BARIUM CHLORIDE	C	C	C	C	C	A	A	A	A	A	C	C	C	B
BARIUM HYDROXIDE	C	B	C	B	C	A	A	A	A	A	C	B	C	B
BARIUM SULFATE	B	B	B	B	B	A	A	A	A	A	B	B	B	A
BARIUM SULFIDE	B	B	B	B	-	A	A	A	A	A	C	B	-	B

(-) – Not tested. VTFEP – Virgin TFE packing.  
 NOTE: All ladings at ambient temperatures except as noted.

## MATERIAL SELECTION GUIDE (CONTINUED)

Lading	STD BDY CS	STD BDY S1	STD BDY CS2	STD BDY S8	SPL BDY CS3	SPL 01	STD 42	SPL 18	SPL 07	STD 43	STD INT CS	STD INT S1	SPL INT S2	SPL INT ML
BEER (ALCOHOL INDUSTRY)	C	A	C	A	C	A	A	A	A	A	C	A	C	A
BEER (BEVERAGE INDUSTRY)	C	A	C	A	C	A	A	A	A	A	C	A	C	A
BEET SUGAR LIQUIDS	B	A	B	A	B	A	A	A	A	A	B	A	B	A
BENZALDEHYDE	A	A	A	A	A	A	A	A	D	A	A	A	A	A
BENZENE (BENZOL)	B	A	B	A	B	A	A	A	A	B	B	A	B	A
BENZOIC ACID	D	B	D	B	D	A	A	A	A	C	D	B	D	B
BORAX LIQUORS	C	B	C	B	C	A	A	A	A	A	C	B	C	A
BORIC ACID	D	A	D	A	D	A	A	A	A	A	D	A	D	A
BRINES	C	B	C	B	C	A	A	A	A	A	C	B	C	A
BROMINE (DRY)	D	D	D	D	D	A	A	A	A	C	D	D	D	A
BROMINE (WET)	D	D	D	D	D	A	A	A	B	D	D	D	D	B
BUNKER OILS (FUEL OILS)	B	A	B	A	B	A	A	A	A	A	B	A	B	A
BUTADIENE	B	A	B	A	B	A	C	D	A	B	B	A	B	C
BUTANE	A	A	A	A	A	A	A	A	A	A	B	A	B	A
BUTTERMILK	D	A	D	A	D	A	A	A	A	A	D	A	D	D
BUTYLENE	A	A	A	A	A	A	A	A	A	B	A	A	A	A
BUTYRIC ACID	D	B	D	B	D	A	A	A	B	C	D	B	D	B
CALCIUM BISULFITE	D	B	D	B	D	A	A	A	B	D	D	B	D	B
CALCIUM CARBONATE	D	B	D	B	D	A	A	A	A	A	D	B	D	B
CALCIUM CHLORIDE	C	B	C	B	C	A	A	A	A	A	C	B	C	A
CALCIUM HYDROXIDE (20%)	B	B	B	B	B	A	A	A	A	A	B	B	B	A
CALCIUM HYPOCHLORITE	D	C	D	C	D	A	A	A	A	D	A	A	D	C
CALCIUM SULFATE	C	B	C	B	C	A	A	A	A	A	C	B	C	B
CARBON BISULFIDE	B	B	B	B	B	A	A	A	A	D	B	B	B	A
CARBON DIOXIDE (DRY)	A	A	A	A	A	A	A	A	D	A	A	A	A	A
CARBON DIOXIDE (WET)	D	B	D	B	-	A	A	A	D	A	D	A	A	A
CARBON TETRACHLORIDE (DRY)	B	A	B	A	B	A	A	A	A	B	B	A	B	A
CARBON TETRACHLORIDE (WET)	D	B	D	B	D	A	A	A	A	C	D	B	D	B
CARBONATED WATER	B	A	B	A	B	A	A	A	A	A	B	A	B	A
CARBONIC ACID	D	B	D	B	D	A	A	A	A	B	D	B	D	A
CASTOR OIL	B	A	B	A	B	A	A	A	A	A	B	A	B	A
CHINA WOOD OIL (TUNG)	C	A	C	A	C	A	A	A	A	A	C	A	C	A
CHLORINATED SOLVENTS (DRY)	C	B	C	B	C	A	A	A	A	B	C	B	C	B
CHLORINE (WET)	D	D	D	D	D	A	A	A	A	D	D	D	D	C
CHLORINE GAS (DRY)	B	B	B	B	B	A	A	A	A	D	B	B	B	B
CHLOROACETIC ACID	D	C	D	C	D	A	A	A	D	D	D	D	D	B
CHLOROBENZENE (DRY)	B	A	B	A	B	A	A	A	A	B	B	A	B	A
CHLOROFORM (DRY)	B	A	B	A	B	A	A	A	A	B	B	A	B	A
CHLOROSULPHONIC ACID (DRY)	B	B	B	B	B	A	A	A	D	D	B	B	B	A
CHLOROSULPHONIC ACID (WET)	D	D	D	D	D	A	A	A	D	D	D	D	D	C
CHROME ALUM	B	A	B	A	B	A	A	A	A	C	B	A	B	B
CHROMIC ACID	D	C	D	C	D	A	A	A	A	D	D	C	D	B
CITRUS JUICES	D	B	D	B	D	A	A	A	A	A	D	B	D	A
COCONUT OIL	C	B	C	B	C	A	A	A	A	A	C	B	C	B
COFFEE EXTRACTS (HOT)	C	A	C	A	C	A	A	A	A	A	C	A	C	A
COKE OVEN GAS	B	A	B	A	B	A	A	A	A	D	B	A	B	B
COOKING OIL	B	A	B	A	B	A	A	A	A	B	B	A	B	A
COPPER ACETATE (10%)	C	B	C	B	C	A	A	A	D	A	C	B	C	B
COPPER CHLORIDE	D	D	D	D	D	A	A	A	A	A	D	D	D	C
COPPER NITRATE	D	B	D	B	D	A	A	A	A	A	D	B	D	C
COPPER SULFATE	D	C	D	C	D	A	A	A	A	B	D	C	D	B
CORN OIL	C	B	C	B	C	A	A	A	A	A	C	B	C	B
CORROSION INHIBITOR – AMINE BASED	A	A	A	A	A	A	A	A	-	B	A	A	A	A
COTTONSEED OIL	C	B	C	B	C	A	A	A	A	A	C	B	C	B
CREOSOTE OIL	B	B	B	B	B	A	A	A	A	C	B	B	B	A
CRYSYLIC ACID	B	B	B	B	B	A	A	A	A	C	B	B	B	B
CRUDE OIL SOUR	B	A	B	A	B	A	A	A	A	B	B	A	B	A
CRUDE OIL SWEET	B	A	B	A	B	A	A	A	A	A	B	A	B	A
CUTTING OILS, WATER EMULSIONS	B	A	B	A	B	A	A	A	A	B	B	A	B	-
CYCLOHEXANE	A	A	A	A	A	A	A	A	A	A	A	A	A	A
DIACETONE ALCOHOL	A	A	A	A	A	A	A	A	D	C	A	A	A	A
DIESEL FUEL	A	A	A	A	A	A	A	A	A	A	A	A	A	A

(-) – Not tested. VTFEP – Virgin TFE packing.

NOTE: All ladings at ambient temperatures except as noted.

Lading	STD BDY CS	STD BDY S1	STD BDY CS2	STD BDY S8	SPL BDY CS3	SPL 01	STD 42	SPL 18	SPL 07	STD 43	STD INT CS	STD INT S1	SPL INT S2	SPL INT ML
DIETHYLAMINE	A	A	A	A	A	A	A	A	HF	C	A	A	A	A
DIPHANTIC ANHYDROUS	-	-	-	-	-	-	A	-	-	-	-	-	-	-
DOWTHERMS (A-E)	B	A	B	A	B	A	A	A	A	B	B	A	B	A
DRILLING MUD	B	A	B	A	B	A	A	A	A	A	B	A	B	A
DRIP COCKS, GAS	B	A	B	A	B	A	A	A	A	A	B	A	B	A
DRY CLEANING FLUIDS	B	A	B	A	B	A	A	A	A	B	B	A	B	B
EPSOM SALT	C	B	C	B	C	A	A	A	A	A	C	B	C	B
ETHANE	A	A	A	A	A	A	A	A	A	A	A	A	A	A
ETHANOLAMINE	A	A	A	A	A	A	A	A	D	C	A	A	A	A
ETHERS	B	A	B	A	B	-	A	A	D	A	B	A	B	B
ETHYL ACETATE	B	B	B	B	B	A	A	A	D	C	B	B	B	B
ETHYL ACRYLATE	A	A	A	A	A	A	A	A	B	C	A	A	A	A
ETHYL CHLORIDE (DRY)	B	A	B	A	B	A	A	A	A	B	B	A	B	B
ETHYL CHLORIDE (WET)	B	B	B	B	B	A	A	A	A	B	B	B	B	B
ETHYLENE (LIQUID OR GAS)	A	A	A	A	A	A	-	-	A	B	A	A	A	A
ETHYLENE GLYCOL	B	B	B	B	B	A	A	A	A	A	B	B	B	B
ETHYLENE OXIDE	B	B	B	B	B	A	A	A	D	B	B	B	B	B
FATTY ACIDS	D	B	D	B	D	A	A	A	A	B	D	B	D	B
FERRIC CHLORIDE	D	D	D	D	D	A	A	A	A	A	D	D	D	C
FERRIC NITRATE	D	C	D	C	D	A	A	A	A	A	D	C	D	C
FERRIC SULFATE	D	B	D	B	D	A	A	A	A	A	D	B	D	B
FERROUS CHLORIDE	D	D	D	D	D	A	A	A	A	A	D	D	D	C
FERROUS SULFATE	D	B	D	B	D	A	A	A	A	A	D	B	D	B
FERROUS SULFATE (SAT)	C	A	C	A	C	A	A	A	-	C	C	A	C	A
FERTILIZER SOLUTIONS	B	B	B	B	B	A	A	A	D	D	B	B	B	B
FISH OILS	B	A	B	A	B	A	A	A	A	A	B	A	B	A
FLUORINE (DRY)	B	A	B	A	B	C	C	C	C	C	B	A	B	A
FLUOROSILICIC ACID	D	C	D	C	D	A	-	-	A	C	D	C	D	C
FOOD FLUIDS - PASTES	C	A	C	A	C	A	A	A	A	A	C	A	C	A
FORMALDEHYDE (COLD)	A	A	A	A	A	A	A	A	D	A	A	A	A	A
FORMALDEHYDE (HOT)	D	B	D	B	D	A	A	A	D	B	D	B	D	B
FORMIC ACID (COLD)	D	B	D	B	D	A	A	A	C	D	D	B	D	B
FORMIC ACID (HOT)	D	D	D	D	D	A	A	A	C	D	D	D	D	B
FREON 12 (DRY)	B	A	B	A	B	A	A	A	B	B	B	A	B	A
FRUIT JUICES	D	A	D	A	D	A	A	A	A	A	D	A	D	A
FUEL JET JP-4	A	A	A	A	A	A	A	A	A	A	A	A	A	A
FUEL JET JP-5 100F	A	A	A	A	A	A	A	A	B	A	A	A	A	A
FUEL JET JP-6 100F	A	A	A	A	A	A	A	A	B	A	A	A	-	A
FUEL OIL	B	A	B	A	B	A	A	A	A	A	B	A	B	A
FUEL RP-1	A	A	A	A	A	A	A	A	A	A	A	A	A	A
FURFURAL	A	B	A	B	A	A	A	A	D	B	A	B	A	A
GALLIC ACID	D	B	D	B	D	A	A	A	A	C	D	B	D	B
GAS (MANUFACTURED)	B	B	B	B	B	A	A	A	A	A	B	B	B	A
GAS ODORIZERS (VTFEP)	B	A	B	A	B	A	A	A	A	-	B	A	B	B
GAS, NATURAL	B	A	B	A	B	A	A	A	A	A	B	A	B	A
GASOLINE, AVIATION	A	A	A	A	A	A	A	A	A	A	A	A	A	A
GASOLINE, SOUR	B	A	B	A	B	A	A	A	A	B	B	A	B	A
GASOLINE, LEADED, LOW OCTANE	A	A	A	A	A	A	A	A	A	A	A	A	A	A
GASOLINE, UNLEADED, LOW OCTANE	A	A	A	A	A	A	A	A	A	A	A	A	A	A
GELATIN	D	A	D	A	D	A	A	A	A	A	D	A	D	A
GLUCOSE	B	A	B	A	B	A	A	A	A	A	B	A	B	A
GLUE	A	A	A	A	A	A	A	A	A	A	A	A	A	A
GLYCERINE - GLYCEROL	B	A	B	A	B	A	A	A	A	A	B	A	B	A
GLYCOLS	B	B	B	B	B	A	A	A	A	A	B	B	B	B
GREASE	A	A	A	A	A	A	A	A	A	A	A	A	A	B
HEPTANE	A	A	A	A	A	A	A	A	A	A	A	A	A	A
HEXANE	A	A	A	A	A	A	A	A	A	A	A	A	A	A
HEXANOL, TERTIARY	A	A	A	A	A	A	A	A	A	B	A	A	A	A
HYDRAULIC OIL PHOSPHATE ESTER	A	A	A	A	A	A	A	A	A	B	A	A	A	A
HYDRAULIC OIL PETROLEUM BASE	A	A	A	A	A	A	A	A	A	A	A	A	A	A
HYDROBROMIC ACID	D	D	D	D	D	A	A	A	A	D	D	D	D	C
HYDROCHLORIC ACID 37% AIR FREE	D	D	D	D	D	A	A	A	B	D	D	D	D	B
HYDROCYANIC ACID	D	B	D	B	D	A	-	-	B	D	D	B	D	A

(-) - Not tested. VTFEP - Virgin TFE packing.  
NOTE: All loadings at ambient temperatures except as noted.

## MATERIAL SELECTION GUIDE (CONTINUED)

Lading	STD BDY CS	STD BDY S1	STD BDY CS2	STD BDY S8	SPL BDY CS3	SPL 01	STD 42	SPL 18	SPL 07	STD 43	STD INT CS	STD INT S1	SPL INT S2	SPL INT ML
HYDROFLUORIC ACID	D	D	D	D	D	A	C	C	D	D	D	D	D	B
HYDROFLUOSILICIC ACID	D	C	D	C	D	A	A	A	A	D	D	C	D	B
HYDROGEN GAS (COLD)	B	A	B	A	B	A	A	A	B	A	B	A	B	A
HYDROGEN PEROXIDE 30% (DILUTE)	D	B	D	B	D	A	A	A	B	D	D	B	D	B
HYDROGEN PEROXIDE 90%	D	B	D	B	D	A	A	A	B	D	D	D	B	D
HYDROGEN SULFIDE (DRY)	D	D	A	A	A	A	A	A	A	A	D	D	A	A
HYDROGEN SULFIDE (WET)	D	D	B	A	B	A	B	A	A	A	D	D	A	A
HYPO (SODIUM THIOSULFATE)	D	A	D	A	D	A	A	A	A	B	D	A	D	B
HYPOCHLORITES, SODIUM	D	C	D	C	D	A	A	A	A	D	D	C	D	B
ILLUMINATING GAS	A	A	A	A	A	A	A	A	-	A	A	A	A	A
INK	D	A	D	A	D	A	A	A	-	A	D	A	D	B
IODINE (WET)	D	D	D	D	D	A	A	A	B	B	D	D	D	D
ISO-OCTANE	A	A	A	A	A	A	A	A	A	A	A	A	A	A
ISODOFORM (DRY)	B	B	B	B	B	A	A	A	-	-	B	B	B	B
SOPROPYL ALCOHOL	B	B	B	B	B	A	A	A	B	B	B	B	-	B
ISOPROPYL ETHER	A	A	A	A	A	A	A	A	D	C	A	A	A	A
KEROSENE	B	A	B	A	B	A	A	A	A	A	B	A	B	A
KETCHUP	D	A	D	A	D	A	A	A	A	A	D	A	D	B
KETONES	A	A	A	A	A	A	A	A	D	A	A	A	A	A
LACQUERS (SOLVENTS)	C	A	C	A	C	A	A	A	D	C	C	A	C	A
LACTIC ACID (CONC. COLD)	D	A	D	A	D	A	A	A	A	B	D	B	D	D
LACTIC ACID (CONC. HOT)	D	B	D	B	D	A	A	A	A	D	D	B	D	D
LACTIC ACID (DILUTE COLD)	D	A	D	A	D	A	A	A	A	A	D	A	D	C
LACTIC ACID (DILUTE HOT)	D	A	D	A	D	A	A	A	A	D	D	B	D	D
LARD OIL	C	A	C	A	C	A	A	A	A	A	C	A	C	B
LEAD ACETATE	D	B	C	B	C	A	A	A	D	C	D	B	D	B
LINOLEIC ACID	B	A	B	A	B	A	A	A	C	C	B	A	B	B
LINSEED OIL	A	A	A	A	A	A	A	A	A	A	A	A	A	B
LIQUEFIED PET GAS (LPG)	B	A	B	A	B	A	A	A	A	A	B	A	B	B
LITHIUM BROMIDE	D	A	D	A	D	D	A	A	-	-	D	A	-	A
LUBRICATING OIL	A	A	A	A	A	A	A	A	A	A	A	A	A	B
MAGNESIUM BISULFATE (10%)	C	A	C	A	C	A	A	A	A	A	C	A	C	B
MAGNESIUM CHLORIDE	C	D	C	D	C	A	A	A	A	C	C	D	C	B
MAGNESIUM HYDROXIDE	B	A	B	A	B	A	A	A	A	A	B	A	B	A
MAGNESIUM HYDROXIDE (HOT)	B	A	B	A	B	A	A	A	B	A	B	A	B	A
MAGNESIUM SULFATE	B	B	B	B	B	A	A	A	A	C	B	B	B	B
MALEIC ACID	B	C	B	C	B	A	A	A	A	C	B	C	B	B
MALEIC ANHYDRIDE	D	A	D	A	D	-	A	A	-	-	D	A	B	A
MALIC ACID	D	A	D	A	D	A	A	A	A	C	D	A	D	B
MAYONNAISE	D	A	D	A	D	A	A	A	A	A	D	A	D	B
MERCAPTANS	A	A	A	A	A	A	A	A	A	-	A	A	A	D
MERCURIC CHLORIDE	D	D	D	D	D	A	A	A	A	A	D	D	D	D
MERCURIC CYANIDE (10%)	D	B	D	B	D	A	A	A	-	B	D	B	D	D
MERCURY	A	A	A	A	A	A	A	A	A	A	A	A	A	C
METHANE	A	A	A	A	A	A	A	A	A	A	A	A	A	A
METHYL ACETATE	A	A	A	A	A	A	A	A	D	B	A	A	A	A
METHYL ACETONE	A	A	A	A	A	A	A	A	D	C	A	A	A	A
METHYL CELLOSOLVE	B	B	B	B	B	A	A	A	D	B	B	B	B	B
METHYL CHLORIDE (DRY)	B	A	B	A	B	A	A	A	A	-	B	A	B	A
METHYL ETHYL KETONE	A	A	A	A	A	A	A	A	D	A	A	A	A	A
METHYL FORMATE	B	B	B	B	B	A	A	A	-	B	B	B	B	B
METHYLAMINE	B	B	B	B	B	A	A	A	-	C	B	B	B	B
METHYLENE CHLORIDE (DRY)	B	B	B	B	B	A	A	A	B	B	B	B	B	B
MILK	D	A	D	A	D	A	A	A	A	A	D	A	D	A
MINE WATERS (ACID)	D	B	D	B	D	A	A	A	B	C	D	B	D	B
MINERAL SPRITS	B	B	B	B	B	A	A	A	A	A	B	B	B	B
MINERAL OIL	B	A	B	A	B	A	A	A	A	A	B	A	B	A
MIXED ACIDS (COLD)	C	A	C	A	C	A	A	A	-	D	C	A	C	B
MOLASSES, CRUDE	A	A	A	A	A	A	A	A	A	A	A	A	A	A
MOLASSES, EDIBLE	A	A	A	A	A	A	A	A	A	A	A	A	A	A
MTBE 100% MAX	B	A	B	A	B	A	B	A	D	B	B	A	A	A
MTBE 40% MAX	A	A	A	A	A	D	A	A	D	B	-	A	A	A
MURIATIC ACID	D	D	D	D	D	A	A	A	A	D	D	D	D	B

(-) - Not tested. VTFEP - Virgin TFE packing.

NOTE: All loadings at ambient temperatures except as noted.

Lading	STD BDY CS	STD BDY S1	STD BDY CS2	STD BDY S8	SPL BDY CS3	SPL 01	STD 42	SPL 18	SPL 07	STD 43	STD INT CS	STD INT S1	SPL INT S2	SPL INT ML
MUSTARD	B	A	B	A	B	A	A	A	A	A	B	A	B	A
NAPHTHA	B	A	B	A	B	A	A	A	A	A	B	A	B	B
NAPHTHALENE	A	A	A	A	A	A	A	A	A	B	A	A	A	B
NICKEL AMMONIUM SULFATE (20%)	D	A	D	A	D	A	A	A	A	A	D	A	D	D
NICKEL CHLORIDE	D	B	D	B	D	A	A	A	A	D	D	B	D	B
NICKEL NITRATE (30%)	D	B	D	B	D	A	A	A	A	C	D	B	D	B
NICKEL SULFATE	D	C	D	C	D	A	A	A	A	C	D	C	D	B
NICOTINIC ACID	B	A	B	A	B	A	A	A	-	C	B	A	B	A
NITRIC ACID (10%) (VTFEP)	D	A	D	A	D	A	B	B	A	D	D	A	D	D
NITRIC ACID (100%) (VTFEP)	A	A	A	A	A	A	B	B	D	D	A	A	A	D
NITRIC ACID (30%) (VTFEP)	D	A	D	A	D	A	B	B	A	D	D	A	D	D
NITRIC ACID (80%) (VTFEP)	D	A	D	A	D	A	B	B	C	D	D	A	D	D
NITRIC ACID ANHYDROUS/AQUEOUS (VTFEP)	A	A	A	A	A	A	B	B	D	D	A	A	A	D
NITROBENZENE	B	B	B	B	B	A	A	A	B	C	B	B	B	B
NITROGEN	A	A	A	A	A	A	A	A	A	A	A	A	A	A
NITROUS ACID (10%)	D	B	D	B	D	A	A	A	A	D	D	B	D	D
NITROUS GASES	B	A	B	A	B	A	A	A	A	B	B	A	B	D
NITROUS OXIDE	A	B	A	B	A	A	A	A	A	A	A	B	A	D
OIL, COTTONSEED	C	B	C	B	C	A	A	A	A	A	C	B	C	B
OIL, PETROLEUM (REFINED)	A	A	A	A	A	A	A	A	A	A	A	A	A	A
OIL, PETROLEUM (SOUR) H <sub>2</sub> S AND CO <sub>2</sub>	D	D	A	A	A	A	A	A	B	A	A	A	A	A
OIL, WATER MIXTURES	B	A	B	A	B	A	A	A	B	A	B	A	B	A
OIL, ANIMAL	A	A	A	A	A	A	A	A	A	A	A	A	A	A
OIL, FISH	B	A	B	A	B	A	A	A	A	A	B	A	B	A
OIL, FUEL	B	A	B	A	B	A	A	A	A	A	B	A	B	A
OIL, LUBE	A	A	A	A	A	A	A	A	A	A	A	A	A	B
OIL, MINERAL	B	A	B	A	B	A	A	A	A	A	B	A	B	A
OLEIC ACID	B	A	B	A	B	A	A	A	A	A	B	A	B	B
OLEUM	B	B	B	B	B	A	A	A	A	D	B	B	B	D
OLIVE OIL	B	A	B	A	B	A	A	A	D	B	B	A	B	A
OXALIC ACID	D	D	D	D	D	A	A	A	B	C	D	D	D	B
OXYGEN	B	A	B	A	B	A	A	A	A	C	B	A	B	A
OZONE (DRY)	A	A	A	A	A	A	A	A	A	C	A	A	A	A
OZONE (WET)	C	A	C	A	C	A	A	A	A	C	C	A	C	A
PAINTS AND THINNERS	A	A	A	A	A	A	A	A	A	B	A	A	A	A
PALM OIL	C	B	C	B	C	A	A	A	A	A	C	B	C	A
PALMITIC ACID	C	A	C	A	C	A	A	A	A	B	C	A	C	B
PARAFFIN	B	A	B	A	B	A	A	A	A	B	B	A	B	A
PARAFORMALDEHYDE	B	B	B	B	B	A	A	A	C	A	B	A	B	B
PENTANE	B	A	B	A	B	A	A	A	A	A	B	A	B	B
PERCHLOROETHYLENE	B	B	B	B	B	A	A	A	A	B	B	B	B	A
PETROLATUM	C	B	C	B	C	A	A	A	A	A	C	B	C	A
PHENOL (CARBOLIC ACID)	B	A	B	A	B	A	A	A	A	B	B	A	B	A
PHENOL RESIN	C	A	C	A	C	A	D	A	A	D	C	A	A	A
PHOSGENE (DRY) (VTFEP)	A	A	A	A	A	-	A	A	B	-	A	A	A	A
PHOSGENE (WET) (VTFEP)	D	A	D	A	D	B	A	A	A	-	D	A	A	A
PHOSPHORIC ACID (10%) COLD	D	B	D	B	D	A	A	A	A	D	D	B	D	B
PHOSPHORIC ACID (10%) HOT	D	D	D	D	D	A	A	A	A	D	D	D	D	C
PHOSPHORIC ACID (50%) COLD	D	B	D	B	D	A	A	A	A	D	D	B	D	C
PHOSPHORIC ACID (50%) HOT	D	D	D	D	D	A	A	A	A	D	D	D	D	C
PHOSPHORIC ACID (85%) COLD	B	A	B	A	B	A	A	A	A	D	B	A	B	A
PHOSPHORIC ACID (85%) HOT	C	A	C	A	C	A	A	A	A	D	C	A	C	A
PHTHALIC ACID	C	B	C	B	C	A	A	A	A	C	C	A	C	A
PHTHALIC ANHYDRIDE	C	B	C	B	C	A	A	A	A	B	C	B	C	C
PICRIC ACID	C	B	C	B	C	A	A	A	A	D	C	B	C	A
PINE OIL	B	A	B	A	B	A	A	A	A	A	B	A	B	A
PINEAPPLE JUICE	C	A	C	A	C	A	A	A	A	A	C	A	C	A
POLY ESTER RESIN (VTFEP)	-	A	-	A	-	-	-	-	-	-	-	A	A	A
POLYETHYLENE FLUFF	B	A	B	A	B	-	-	-	-	-	-	A	A	A
POLYETHYLENE LIQUID	B	A	-	A	-	-	-	-	A	-	B	A	A	A
POLYURETHANE	A	A	A	A	A	-	A	A	D	D	A	A	A	A
POTASSIUM BISULFITE (10%)	D	B	D	B	D	A	A	A	A	A	D	D	B	A

(-) – Not tested. VTFEP – Virgin TFE packing.  
NOTE: All loadings at ambient temperatures except as noted.

## MATERIAL SELECTION GUIDE (CONTINUED)

Lading	STD BDY CS	STD BDY S1	STD BDY CS2	STD BDY S8	SPL BDY CS3	SPL 01	STD 42	SPL 18	SPL 07	STD 43	STD INT CS	STD INT S1	SPL INT S2	SPL INT ML
POTASSIUM BROMIDE	D	B	D	B	D	A	A	A	-	A	D	B	D	B
POTASSIUM CARBONATE	C	A	C	A	C	A	A	A	A	A	C	A	C	B
POTASSIUM CHLORATE	B	A	B	A	B	A	A	A	A	A	B	A	B	B
POTASSIUM CHLORIDE	C	A	C	A	C	A	A	A	A	A	C	A	C	B
POTASSIUM CYANIDE	B	B	B	B	B	A	A	A	A	C	B	B	B	B
POTASSIUM DICHROMATE	B	A	B	A	B	A	A	A	A	C	B	A	B	B
POTASSIUM DIPHOSPHATE	A	A	A	A	A	A	A	A	A	A	A	A	A	B
POTASSIUM FERRICYANIDE	B	A	B	A	B	A	A	A	A	A	B	B	B	B
POTASSIUM FERROCYANIDE	B	A	B	A	B	A	A	A	A	A	B	A	B	A
POTASSIUM HYDROXIDE 70% (COLD)	B	B	B	B	B	A	B	B	D	C	B	B	B	A
POTASSIUM HYDROXIDE 70% (HOT)	A	A	A	A	A	A	B	B	D	C	A	A	A	A
POTASSIUM HYDROXIDE-DILUTE (COLD)	B	B	B	B	B	A	A	A	C	A	B	B	B	A
POTASSIUM HYDROXIDE-DILUTE (HOT)	B	A	B	A	B	A	B	B	D	B	B	B	B	A
POTASSIUM IODIDE	C	B	C	B	C	A	A	A	A	A	C	B	C	A
POTASSIUM NITRATE	B	A	B	A	B	A	A	A	A	A	B	A	B	A
POTASSIUM PERMANGANATE	A	A	A	A	A	A	A	A	A	C	A	A	A	B
POTASSIUM SULFATE	B	A	B	A	B	A	A	A	A	C	B	A	B	B
POTASSIUM SULFIDE (10%)	C	B	C	B	C	A	A	A	A	A	C	B	C	D
POTASSIUM SULFITE (10%)	D	A	D	A	D	A	A	A	A	A	D	A	D	D
PRODUCER GAS	B	A	B	A	B	A	A	A	A	A	B	A	B	A
PROPANE	A	A	A	A	A	A	A	A	A	A	A	A	A	A
PROPLENE	-	A	-	A	-	-	-	-	A	-	-	A	A	A
PROPYL ALCOHOL	A	A	A	A	A	A	A	A	A	A	A	A	A	A
PROPYLENE GYLCOL	A	A	A	A	A	A	A	A	A	A	A	A	A	A
PYROGALLIC ACID	B	B	B	B	B	A	A	A		D	B	B	B	B
QUENCH OIL (WATER SOLUBLE)	A	A	A	A	A	A	A	A	B	B	A	A	A	-
RESINS-ROSINS	C	A	C	A	C	A	A	A		B	C	A	C	A
ROAD TAR	A	A	A	A	A	A	A	A	A	B	A	A	A	A
ROOF PITCH	A	A	A	A	A	A	A	A	A	B	A	A	A	A
RUBBER LATEX EMULSIONS	B	A	B	A	B	A	A	A	A	A	B	A	B	-
RUBBER SOLVENT	A	A	A	A	A	A	A	A	D	B	A	A	A	A
SALAD OIL	C	B	C	B	C	A	A	A	A	A	C	B	C	B
SALICYLIC ACID	D	A	D	A	D	A	A	A	A	B	D	A	D	A
SALT	C	B	C	B	C	A	A	A	A	A	C	B	C	A
SEAWATER	D	A	D	A	D	A	A	A	A	A	D	A	D	A
SHELLAC (BLEACHED)	A	A	A	A	A	A	A	A	D	B	A	A	A	A
SHELLAC (ORANGE)	A	A	A	A	A	A	A	A	D	B	A	A	A	A
SILICONE OILS	A	A	A	A	A	A	A	A	A	A	A	A	A	A
SILVER NITRATE	D	B	D	B	D	A	A	A	A	B	D	B	D	D
SOAP SOLUTIONS (STEARATES)	A	A	A	A	A	A	A	A	A	A	A	A	A	A
SODIUM ACETATE	B	B	B	B	B	A	A	A	D	B	B	B	B	B
SODIUM ALUMINATE	C	A	C	A	C	A	A	A	A	A	C	A	C	A
SODIUM BICARBONATE	C	B	C	B	C	A	A	A	A	A	C	B	C	B
SODIUM BISULFATE (10%)	D	A	D	A	D	A	A	A	A	A	D	A	D	B
SODIUM BISULFITE (10%)	D	D	D	D	D	A	A	A	A	A	D	D	D	B
SODIUM BORATE	C	D	C	D	C	A	A	A	A	A	C	D	C	B
SODIUM BROMIDE (10%)	C	B	C	B	C	A	A	A	A	A	C	B	C	B
SODIUM CARBONATE	B	B	B	B	B	A	A	A	A	A	B	B	B	A
SODIUM CHLORATE	C	B	C	B	C	A	A	A	A	A	C	B	C	B
SODIUM CHLORIDE	C	B	C	B	C	A	A	A	A	A	C	B	C	A
SODIUM CHROMATE	B	B	B	B	B	A	A	A	A	D	B	B	B	B
SODIUM CYANIDE (10%)	A	A	A	A	A	A	A	A	A	B	A	A	A	B
SODIUM FLUORIDE	D	B	D	B	D	A	A	A	A	A	D	B	D	A
SODIUM HYDROXIDE 20% (COLD)	A	A	A	A	A	A	A	A	B	A	A	A	A	A
SODIUM HYDROXIDE 20% (HOT)	C	B	C	B	C	A	B	B	C	B	C	B	C	A
SODIUM HYDROXIDE 50% (COLD)	B	B	B	B	B	A	C	C	C	A	B	B	B	A
SODIUM HYDROXIDE 50% (HOT)	B	B	B	B	B	A	C	C	C	B	B	B	B	A
SODIUM HYDROXIDE 70% (COLD)	C	B	C	B	C	A	C	C	C	C	C	B	C	B
SODIUM HYDROXIDE 70% (HOT)	B	B	B	B	B	A	D	D	C	C	B	B	B	B
SODIUM HYPOCHLORIDE	D	D	D	D	D	A	A	A	A	D	D	D	D	D
SODIUM METAPHOSPHATE	A	B	A	B	A	A	A	A	A	A	A	B	A	B
SODIUM METASILICATE (HOT)	D	A	D	A	D	A	A	A	-	A	D	A	D	A

(-) – Not tested. VTFEP – Virgin TFE packing.

NOTE: All ladings at ambient temperatures except as noted.



Lading	STD	STD	STD	STD	SPL	SPL	STD	SPL	SPL	STD	STD	STD	SPL	SPL	
	BDY	BDY	BDY	BDY	BDY	BDY	01	42	18	07	43	INT	INT	INT	ML
	CS	S1	CS2	S8	CS3							CS	S1	S2	ML
SODIUM METASILICATE (COLD)	C	A	C	A	C	A	A	A	-	A	C	A	C	A	A
SODIUM NITRATE	B	B	B	B	B	A	A	A	-	C	B	B	B	B	B
SODIUM PERBORATE	B	B	B	B	B	A	A	A	A	A	B	B	B	B	B
SODIUM PEROXIDE	C	B	C	B	C	A	A	A	A	B	C	B	C	B	B
SODIUM PHOSPHATE (DIBASIC)	B	B	B	B	B	A	A	A	A	A	B	B	B	B	B
SODIUM PHOSPHATE (TRIBASIC)	B	B	B	B	B	A	A	A	A	A	B	B	B	B	B
SODIUM SILICATE	A	A	A	A	A	A	A	A	A	A	A	A	A	A	B
SODIUM SILICATE (HOT)	B	B	B	B	B	A	A	A	A	A	B	B	B	B	B
SODIUM SULFATE NA <sub>2</sub> SO <sub>4</sub>	B	A	B	A	B	A	A	A	A	A	B	A	B	A	A
SODIUM SULFIDE (HOT)	C	B	C	B	C	A	A	A	A	A	C	B	C	B	B
SODIUM SULFIDE NA <sub>2</sub> SO <sub>2</sub>	B	B	B	B	B	A	A	A	A	A	B	B	B	B	A
SODIUM THIOSULFATE	D	B	D	B	D	A	A	A	A	A	D	B	D	B	B
SOUR GAS AND OIL	D	D	A	A	A	A	A	A	A	A	D	D	A	A	A
SOYBEAN OIL	C	A	C	A	C	A	A	A	A	A	C	A	C	A	A
STANNIC CHLORIDE	D	D	D	D	D	A	A	A	A	B	D	D	D	D	C
STANNOUS CHLORIDE	D	C	D	C	D	A	A	A	A	D	D	C	D	C	C
STARCH	A	A	A	A	A	A	A	A	A	A	A	A	A	A	A
STEAM (212° F)	B	A	B	A	B	B	C	A	D	D	B	A	A	A	A
STEARIC ACID	C	A	C	A	C	A	A	A		B	C	A	C	B	B
STODDARD SOLVENT	B	B	B	B	B	A	A	A	A	A	B	B	B	B	B
STYRENE	A	A	A	A	A	B	D	D	D	B	A	A	A	A	A
SUGAR LIQUIDS	B	A	B	A	B	A	A	A	A	A	B	A	B	A	A
SULFATE, BLACK LIQUORS	C	B	C	B	C	A	A	A	B	B	C	B	C	B	B
SULFATE, GREEN LIQUORS	C	B	C	B	C	A	A	A	A	B	C	B	C	B	B
SULFATE, WHITE LIQUORS	D	B	D	B	D	A	A	A	A	B	D	B	D	B	B
SULFURIC ACID (0 to 7%) (VTFEP)	D	B	D	B	D	A	A	A	A	D	D	B	D	B	B
SULFURIC ACID (100%) H <sub>2</sub> SO <sub>4</sub> (VTFEP)	B	B	B	B	B	A	A	A	B	D	B	B	B	B	D
SULFURIC ACID (20%) (VTFEP)	D	D	D	D	D	A	A	A	A	D	D	D	D	D	B
SULFURIC ACID (50%) (VTFEP)	D	D	D	D	D	A	A	A	A	D	D	D	D	D	B
SULFUROUS ACID	D	D	D	D	D	A	A	A	A	D	D	D	D	D	D
SULPHUR	B	A	B	A	B	A	A	A	A	C	B	A	B	A	A
SULPHUR DIOXIDE (DRY)	B	A	B	A	B	A	A	A	A	A	B	A	B	A	A
SULPHUR TRIOXIDE (DRY)	B	B	B	B	B	A	A	A	A	B	B	B	B	B	B
SYNTHESIS GAS	B	B	B	B	B	A	A	A	A	A	B	B	B	B	A
TALL OIL	B	B	B	B	B	A	A	A	A	A	B	B	B	B	A
TANNIC ACID	B	B	B	B	B	A	A	A	A	A	B	B	B	B	B
TAR – TAR OIL	A	A	A	A	A	A	A	A	A	B	A	A	A	A	A
TARTARIC ACID	D	B	D	B	D	A	A	A	A	B	D	B	D	B	B
TETRAETHYL LEAD	C	B	C	B	C	A	A	A	A	B	C	B	C	A	A
TITANIUM TETRACHLORIDE T1-CL4	-	-	-	-	-	-	-	-	-	-	-	-	-	-	-
TITANIUM TRICHLORIDE T1-CL3	-	-	-	-	-	-	-	-	-	-	-	-	-	-	-
TOLUENE – TOLUOL	A	A	A	A	A	A	A	A	A	B	A	A	A	A	A
TOMATO JUICE	C	A	C	A	C	A	A	A	A	A	C	A	C	A	A
TRANSFORMER OIL	A	A	A	A	A	A	A	A	A	A	A	A	A	A	A
TRIBUTYL PHOSPHATE	A	A	A	A	A	A	A	A	D	B	A	A	A	A	A
TRICHLOROETHYLENE	B	B	B	B	B	A	A	A	B	B	B	B	B	B	A
TUNG OIL	B	A	B	A	B	A	A	A	A	A	B	A	B	C	C
TURPENTINE	B	A	B	A	B	A	A	A	A	A	B	A	B	B	B
UREA	C	B	C	B	C	A	A	A	-	-	C	B	C	A	A
VARNISH	C	A	C	A	C	A	A	A	B	B	C	A	C	A	A
VEGETABLE OIL, EDIBLE	B	A	B	A	B	A	A	A	A	A	B	A	B	B	B
VEGETABLE OIL, NON-EDIBLE	B	A	B	A	B	A	A	A	A	A	B	A	B	B	B
VINEGAR	D	A	D	A	D	A	A	A	A	A	D	A	D	A	A
WATER, DISTILLED (AREATED)	D	A	D	A	D	A	A	A	A	A	D	A	D	A	A
WATER, FRESH	C	A	C	A	C	A	A	A	A	A	C	A	C	A	A
WATER, SEA	D	A	D	A	D	A	A	A	A	A	D	A	D	A	A
WAX, EMULSIONS	A	A	A	A	A	A	A	A	A	A	A	A	A	-	-
WAXES	A	A	A	A	A	A	A	A	A	A	A	A	A	A	A
WHISKEY AND WINE	D	A	D	A	D	A	A	A	A	A	D	A	D	A	A
XYLENE (DRY)	A	A	A	A	A	A	A	A	A	A	A	A	A	A	A
ZINC CHLORIDE	D	D	D	D	D	A	A	A	A	C	D	D	D	B	B
ZINC HYDROSULFITE	A	A	A	A	A	A	A	A	A	D	A	A	A	B	B
ZINC SULFATE	D	B	D	B	D	A	A	A	A	D	D	B	D	B	B

(-) – Not tested. VTFEP – Virgin TFE packing.  
NOTE: All ladings at ambient temperatures except as noted.

## CAMSERV™ Services for Valves and Actuation

WE BUILD IT. WE BACK IT.



### Global Network and Local Support

Cameron is well-positioned to deliver total aftermarket support, quickly and efficiently, with unmatched OEM expertise. Our highly skilled engineers and technicians are available around the clock, seven days a week to respond to customer queries, troubleshoot problems and offer reliable solutions.

### Easily Accessible Parts and Spare Valves

- OEM spare valves, actuators and parts (including non-Cameron brands)
- Handling, storage, packaging and delivery
- Dedicated stocking program



### Comprehensive Aftermarket Services Portfolio

- Parts and spare valves
- Repair
- Field services
- Preventative maintenance
- Equipment testing and diagnostics
- Remanufacturing
- Asset preservation
- Customer property management
- Training and recertification services
- Warranty



### Customized Total Valve Care<sup>SM</sup> (TVC) Programs

Customized asset management plans that optimize uptime, availability and dedicated services.

- Engineering consultancy
- Site management
- Flange management
- Startup and commissioning
- Spare parts and asset management
- Operational support



## Trademark Information

WKM is a registered trademark of Cameron. CAMSERV and DynaSeal are trademarks of Cameron.

This document contains references to registered trademarks or product designations that are not owned by Cameron.

Trademark	Owner	Common Name	Comparable Cameron Abbreviated Name (in trim charts)
Celcon	Hoechst Celanese Corporation		
Teflon	E.I. DuPont De Nemours & Company	Poly Tetra Fluoro Ethylene	PTFE
Viton	DuPont Dow Elastomers L.L.C.	Fluoroelastomer	FKM
17-4PH	Armco Advanced Materials Corp.	17-4PH Stainless Steel	Type 630
		Electroless Nickel Plating	ENP

3250 Briarpark Drive, Suite 300  
Houston, TX 77042  
USA  
Toll Free 1.800.323.9160

Learn more about WKM at:  
[www.c-a-m.com/valves](http://www.c-a-m.com/valves)



#### **HSE Policy Statement**

At Cameron, we are committed ethically, financially and personally to a working environment where no one gets hurt and nothing gets harmed.