

# CAMERON® Fully Welded Ball Valves

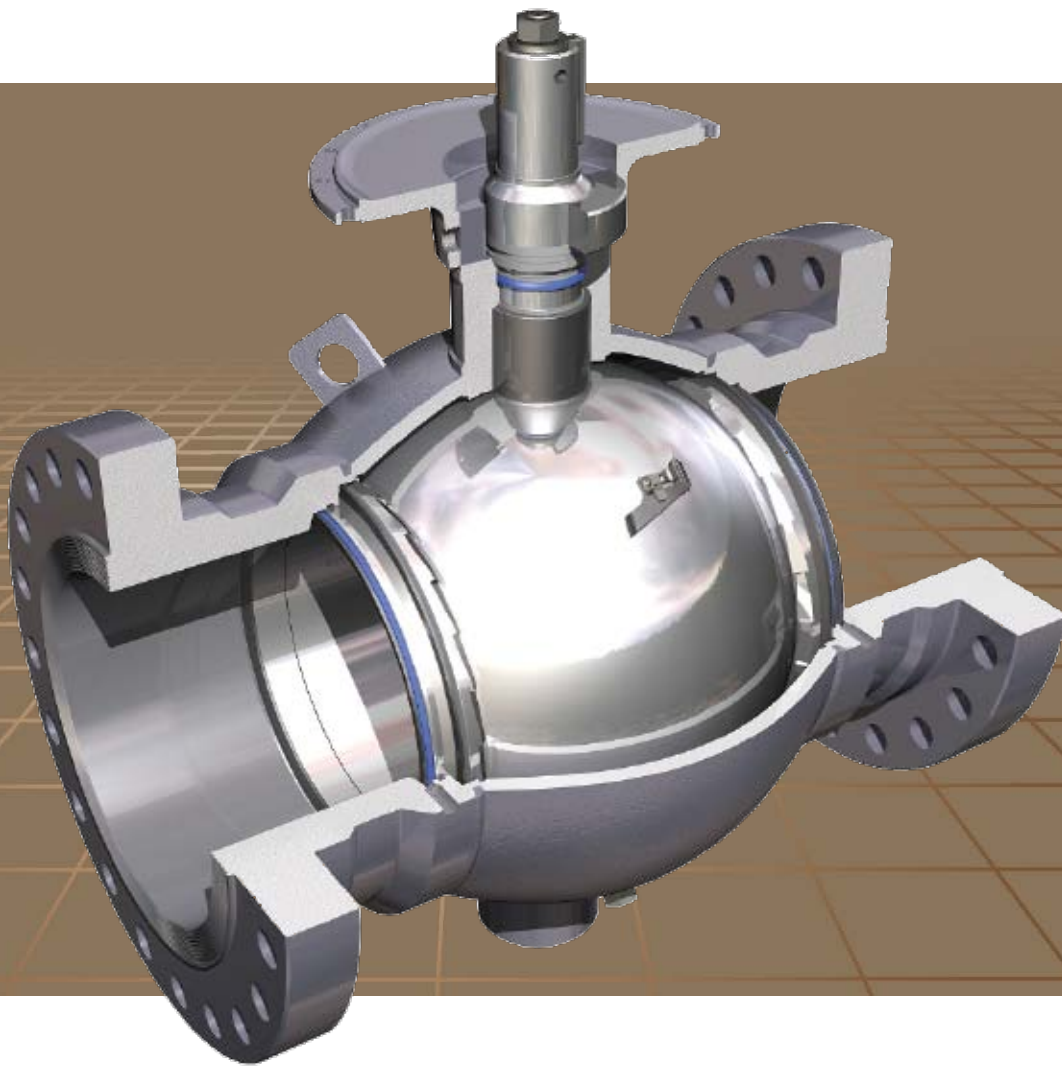



## TABLE OF CONTENTS

### CAMERON FULLY WELDED BALL VALVES

Introduction.....	4
Features and Benefits .....	5
Standard Seat Design.....	8
Alternate Seat Design .....	9
Accessories .....	10
How to Order .....	11
Standards, Specifications and Materials.....	12

### DIMENSION TABLES

#### ASME / ANSI Class 150 through 2500 (PN 20 through PN 420)

Full and Reduced Port Valves.....	14
-----------------------------------	----

#### API PRESSURE CLASS 2000, 3000 & 5000 PSI

Full Port Valves.....	27
Reduced Port Valves.....	28
Dimensional Data.....	29
Top Works Dimensions .....	30
Top Works Dimensions - Manual Gear Dimensions.....	32
Aftermarket Services .....	33
Trademark Information .....	34



Ville Platte, Louisiana

**Cameron's Valves & Measurement (V&M)** group is a leading provider of valves and measurement systems to the oil and gas industry. The group's products are primarily used to control, direct and measure the flow of oil and gas as it is moved from individual wellheads through flow lines, gathering lines and transmission systems to refineries, petrochemical plants and industrial centers for processing.

The Engineered & Process Valves division provides a wide range of valves for use in natural gas, LNG, crude oil and refined products transmission lines. The traditional CAMERON® fully-welded ball valve product line has been combined with the GROVE®, RING-O®, TOM WHEATLEY®, ENTECH™ and TK® product lines. This broad offering has significantly strengthened Cameron's ability to serve as a single source for a wide scope of customer requirements. The division also provides critical service valves for refinery, chemical and petrochemical processing businesses and for associated storage terminal applications, particularly through the ORBIT® and GENERAL VALVE® product lines. These brands are complimented by WKM®, TBV™, and TEXSTEAM™ valve products and considerably expand the scope of this division's product offerings.

## CAMERON FULLY WELDED BALL VALVES

### FEATURES AND BENEFITS

One of the most trusted valves in the petroleum industry, these valves combine the strength of forged components with a lightweight and compact spherical design.

CAMERON fully welded ball valves satisfy ASME/ANSI 150 through 2500 (PN 20 through PN 420) and API 2000 through 10,000 standards. Made of forged steel to assure uniform fine grain structure and toughness, they may be specified in sizes from 2 in. to 56 in. (50 mm to 1400 mm).

Engineered for heavy duty, maintenance free performance, the CAMERON fully welded ball valve is commonly selected for a number of applications, including:

- Gas transmission
- Products pipeline
- Measurements skids
- Dehydration systems
- Gas separation systems
- Natural gas storage
- Dryer service
- NGL plants
- NGL pipeline
- Compressor stations
- CO<sub>2</sub> services
- Offshore
- Subsea

The distinctive design of the CAMERON fully welded ball valve gives it maximum strength at minimum weight as well as maximum resistance both to pipeline pressures and stresses. The compact, spherical design also eliminates body flanges, thus reducing overall size and potential leak paths.

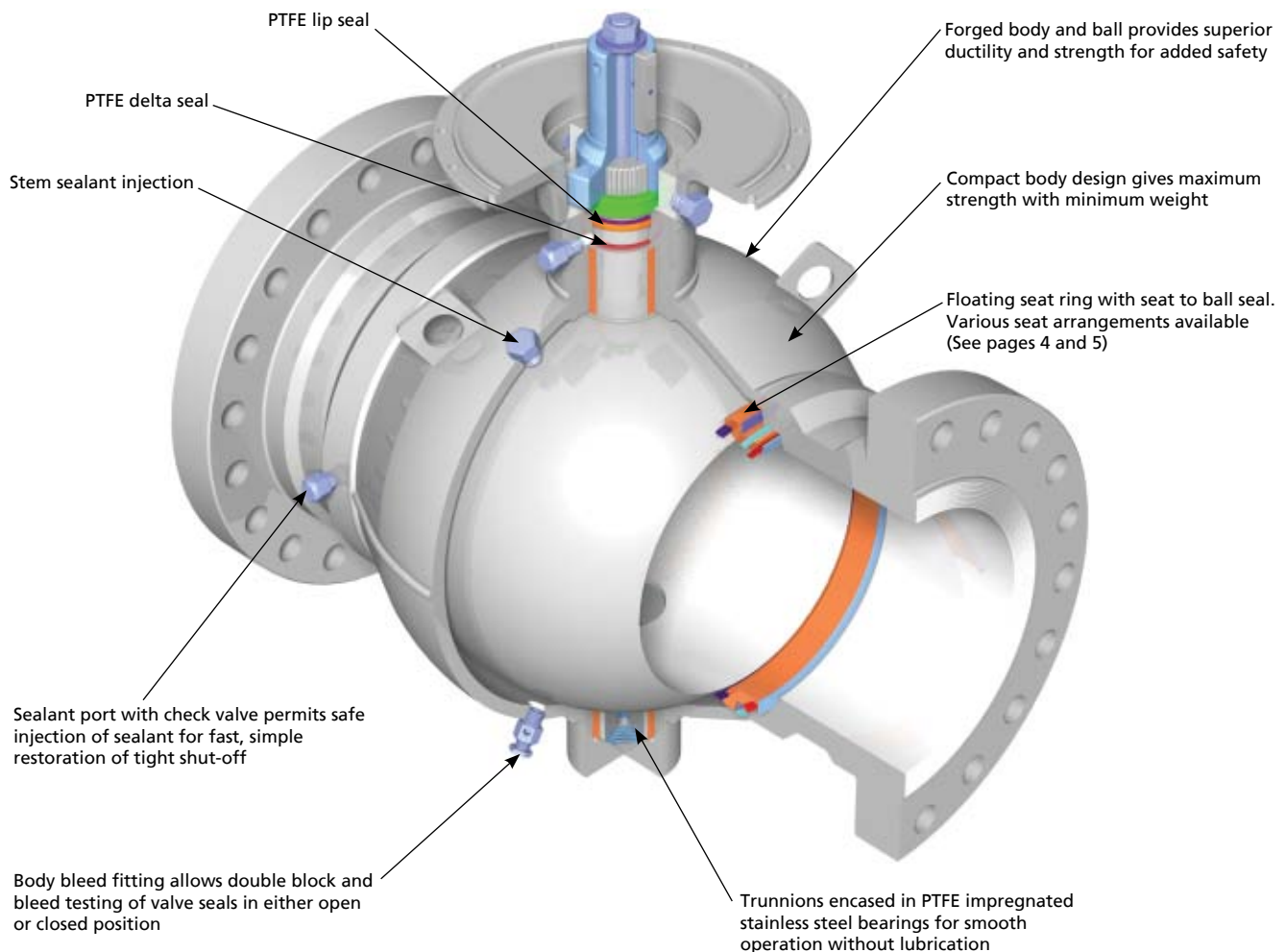

## CAMERON FULLY WELDED BALL VALVES

### FEATURES AND BENEFITS (Cont.)

#### Replace Stem Seal

In the unlikely event of a stem seal needing replacement, it can be accomplished safely with the valve in service.

With the body cavity vented all line pressure to the stem area is also vented. (Please contact your Valves & Measurement Group representative to obtain maintenance procedures.)

#### Safeguard Downstream Work

With the valve closed and the vent fitting open, the possibility of the line media reaching a work area is almost completely removed.

#### Fire Tested for Safety

CAMERON fully welded ball valves can be supplied to API 6FA, API 607 and ISO 10497 standards. Fire test programs are ongoing. If industry standards change or customer requirements vary from the above, call your Valves & Measurement Group representative.

#### Standards & Specifications\*

##### Sizes

- 2 in. through 56 in. (50 mm through 1400 mm) full, reduced and Venturi Bore

##### Pressure Classes

- ASME / ANSI Class 150 through 2500 (PN 20 through PN 420) API 2000 through 10,000 psi

##### Operating Temperatures

- From -50° F to 375° F (-46° C to 190° C)

##### End Connections

- Flanged, weld and weld by flange, etc.

##### Body Styles

- Fully welded

##### Standard Material

- Forged carbon steel

##### Optional Materials

- Seat/seal trim options include: regular, corrosion resistant and sour (NACE MR0175)

\* See page 8 for specification details.

## CAMERON FULLY WELDED BALL VALVES

### FEATURES AND BENEFITS (Cont.)

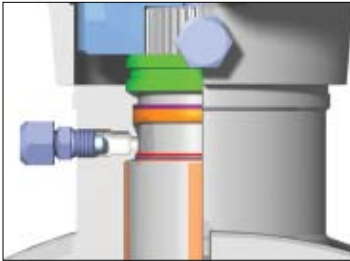

#### Stem Seals

Delta seals and lip seals made of PTFE are incorporated in the upper stem area. PTFE is a low friction, non-deteriorating material that is not subject to rapid decompression explosion. Most valve sizes have a provision for the injection of sealant to establish a secondary seal.

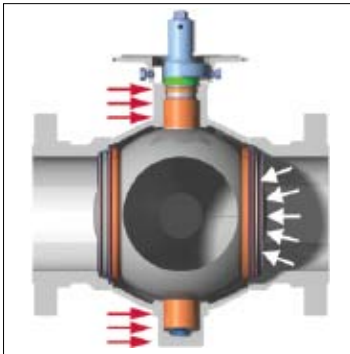

#### Trunnion Supported Ball Allows Low Torque Operation

Regardless of size or pressure rating, every CAMERON ball valve is trunnion mounted. High strength forged stems are located in PTFE impregnated stainless steels bearings for smooth, accurate operations. Trunnion mounted stems absorb the thrust from line pressure, preventing excess friction between the ball and seats, so even at full rated working pressure, operating torque stays low.

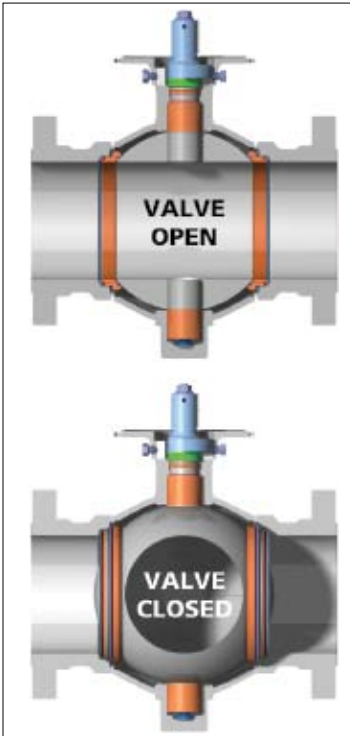

#### Double Block-and-Bleed

Whether in the fully open or fully closed position, pressure on each side of the ball is blocked from the body cavity by the seat ring.

The body cavity can then be bled down or drained through the body port.

When you block-and-bleed a CAMERON ball valve the following can be accomplished:

#### Test Valve Integrity

When the valve body is vented this verifies the seat seal's integrity.

This test can be performed with the valve open or closed.

By verifying valve seat seal integrity valve performance can be validated.

#### Secondary Seat Seal

The sealant injection system provides a fast, simple way of restoring tight shut off if any foreign object should damage the sealing surfaces.

The injection system can also be used for routine flushing of the seat ring area in services where this may be required.

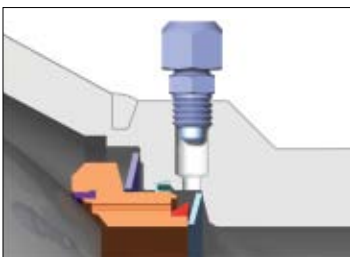



## CAMERON FULLY WELDED BALL VALVES

### STANDARD SEAT DESIGN

In service since the early 1960s, the standard seat arrangement has proven itself to be of sound design. This arrangement is available in all CAMERON fully welded ball valves and includes the features and benefits indicated on the preceding pages.

#### Features and Benefits

##### Upstream Sealing

At low pressure, seat to ball contact is maintained by Belleville springs. At higher pressures, seat contact is reinforced by line pressure.



##### Automatic Internal Relief of Body Pressure

Relief of excess body cavity pressure is automatic, avoiding dangerous pressure build up. Any pressure exceeding downstream line pressure by approximately 200 psi pushes the downstream seat away from the ball, allowing the pressure to relieve into the pipeline.

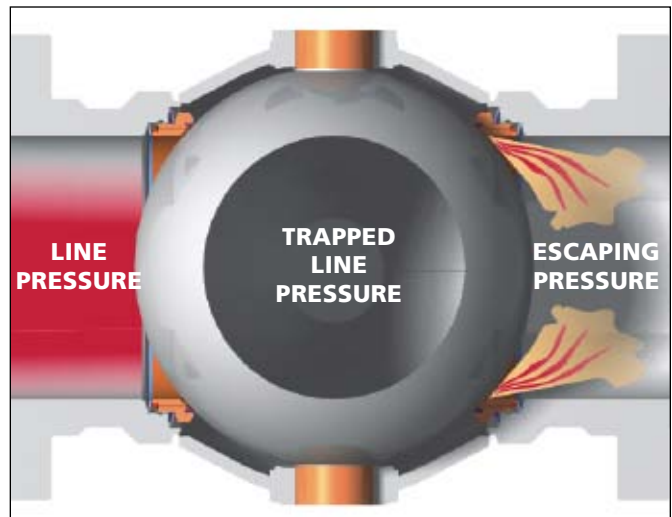

##### Rotating Seat Rings

A standard in the CAMERON fully welded ball valve sizes 14 in. (350 mm) and larger, the CAMERON fully welded ball valve incorporates the exclusive rotating seat feature. Both seats rotate 15 degrees each time the valve is closed, exposing a new pinch point, evenly distributing seat wear.

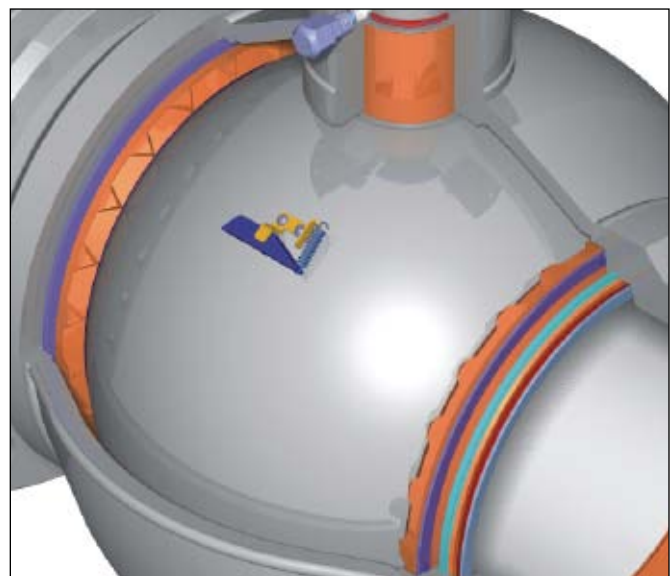

##### Distributed Seat Wear

The pinch point is the area of the seat insert that experiences an increased velocity when the valve is seated closed and unseated open. This is where the seat seal experiences the most wear, and in most valves where a leak path begins. By rotating the seat ring, the pinch point wear is distributed throughout the seat seal providing a substantial increase in seat life.

##### Prevents Build Up

In some services a valve can experience harmful sediment build up around the seat ring. This can cause the seat to stick and not seal properly. The CAMERON fully welded ball valves, with exclusive rotating seat, can handle these harsher services. As the seat rotates it will prevent any build up, or breaks up existing build up.



## CAMERON FULLY WELDED BALL VALVES

### ALTERNATE SEAT DESIGN

The CAMERON fully welded ball valve is available with double acting and metal to metal seats to accommodate a variety of applications and customer preferences.

#### Double Acting

##### Conventional Upstream Sealing

With the upstream pressure, the bidirectional body to seat seal is pushed toward the front sealing face of its retaining pocket. This creates an unbalanced pressure annulus between the body seal and the inside diameter of the seat insert, forcing the seat insert against the ball.

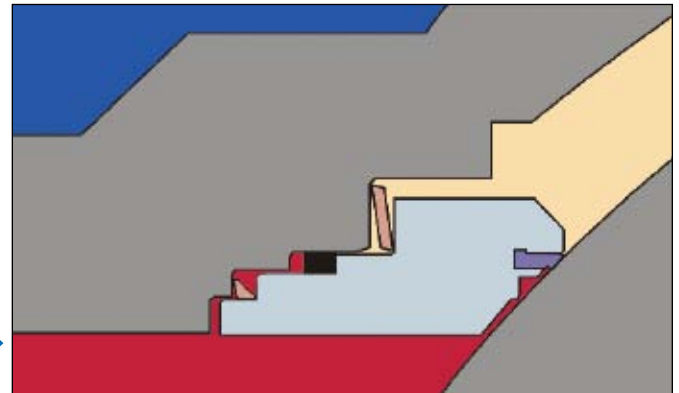

##### Downstream Sealing

With the downstream pressure, the bidirectional body to seat seal is pushed toward the back sealing face of its retaining pocket. This creates an unbalanced pressure annulus between the outside diameter of the seat insert and the body seal diameter, also forcing the seat insert against the ball.



#### Metal-to-Metal

##### For Severe Service Applications

Where a soft seat insert would be unsuitable, a metal-to-metal design can be provided. In this design both the seat and the ball are coated with Tungsten Carbide which is resistant to corrosion and wear making it suitable for abrasive services. This type of seat is upstream sealing and incorporates internal relief of body pressure.

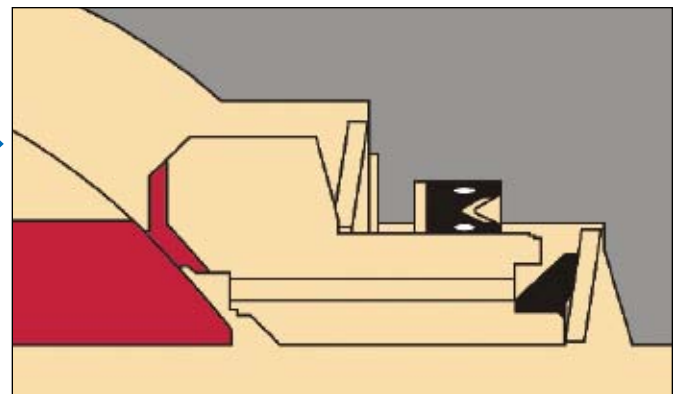

### Standards and Specifications

#### Double Acting - T32

##### SIZES

- 8 in. (200 mm) - 48 in. (1200 mm)

##### PRESSURE CLASSES

- ASME/ANSI Class 150 - 900 (PN 20 - PN 150)

##### OPERATING TEMPERATURES

- -50° F to 250° F (-46° C to 121° C)

#### Metal-To-Metal - T34

##### SIZES

- 2 in. (50 mm) - 48 in. (1200 mm)

##### PRESSURE CLASSES

- ASME/ANSI Class 150 (PN 20) - API 10,000

##### OPERATING TEMPERATURES

- -50° F to 375° F (-46° C to 190° C)

## CAMERON FULLY WELDED BALL VALVES ACCESSORIES

Quality Cameron accessories are available to improve the CAMERON fully welded ball valve's adaptability to a wide variety of situations.

### High Head for Remote Operation

For situations in which the CAMERON fully welded ball valve must be underground, the CAMERON high head makes the controls accessible above ground.

Designed and constructed to withstand punishing environments, it has proven itself in uses all over the world for many years.

### Subsea Design Offers Important Benefits

For the same reliable performance offshore as on, the CAMERON fully welded ball valve is available with a coating and actuation designed specifically for the demands of a subsea environment.

### Right Angle Improves Flexibility

CAMERON fully welded ball valves can be specified for tight spaces when fitted with a CAMERON right angle extension.

The valve control is turned 90 degrees from its usual position, allowing more space at the top of the valve and better access by operators.

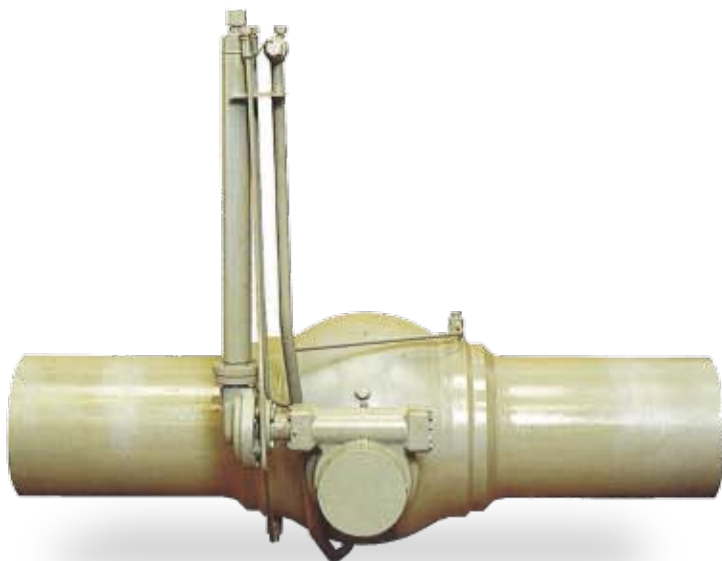

# CAMERON FULLY WELDED BALL VALVES

## HOW TO ORDER

Specify the following when ordering a CAMERON Fully Welded Ball Valve:

1. Valve figure number (see chart below).
  2. Pressure classification (ASME/ANSI 600 lb, API 3000 psi).
  3. End and bore sizes.
  4. Type of end connections (unequal ends can be furnished). For weld end valves, specify I.D. or O.D., wall thickness and grade of pipe.
  5. Type of operator.
  6. Stem extension, if desired. Specify distance from valve centerline to center of handwheel, or top of power operator mounting flange.
  7. Type of trim or application.
  8. Accessories, if desired (lifting eyes, locking devices, etc.). Handwheels are included with valves, but operating levers must be ordered separately.
- Information on special trims and API configurations is available upon request.

Specify the following when ordering another manufacturer's power operator to fit a CAMERON Fully Welded Ball Valve:

1. Valve size and pressure class and, if for field conversion, the present operator.
2. Maximum differential pressure across valve during operation and any abnormal operating conditions.
3. Speed of opening and closing, probable frequency of operation.
4. Type operator desired (electric, hydraulic, pneumatic).
5. Information on operating medium. If electric-voltage, frequency, single or three phase, open or explosion proof motor. If hydraulic or pneumatic-operating medium, pressure.
6. Accessories and controls; limit switches, valving, instrumentation, tanks, pumps, etc.

80		06		0		1		-		2		-		1	
Classification		Pressure Classification		Bore		End Connections				Operator				Trim	
80	ASME/ANSI	01	ASME/ANSI 150	0	Full	1	Lever	1		1	Standard (150-1500)	1		1	Standard (150-1500)
81	API	03	ASME/ANSI 300	7	Reduced	1A	Extension lever	2		2	Standard API (2000-5000)	2		2	Standard API (2000-5000)
82	AFNOR	04	ASME/ANSI 400	4	Venturi	2	Worm gear	4		4	Hi-temp Teflon (150-600)	4		4	Hi-temp Teflon (150-600)
83	DIN	06	ASME/ANSI 600	9	All Others	2A	Extension worm gear	8		8	Lo-temp Nylon (150-2500)	8		8	Lo-temp Nylon (150-2500)
84	UNI	09	ASME/ANSI 900			4	Subsea gear	123		123	Pressure regulating (150-1500)	123		123	Pressure regulating (150-1500)
		15	ASME/ANSI 1500			4A	Subsea gear 300 feet +	212		212	NACE (150-2500)	212		212	NACE (150-2500)
		25	ASME/ANSI 2500			7	Direct stem	213		213	NACE (2000-5000)	213		213	NACE (2000-5000)
		20	API 2000			7A	Extension direct stem	214		214	Tefzel/NACE (150-1500)	214		214	Tefzel/NACE (150-1500)
		30	API 3000			8	Worm gear/adapted	215		215	Tefzel/NACE (2000-5000)	215		215	Tefzel/NACE (2000-5000)
		50	API 5000			8A	Extension worm gear/adapted	216		216	NACE/Lo-temp (150-2500)	216		216	NACE/Lo-temp (150-2500)
				1	RF/RF	22	Square	217		217	NACE/Lo-temp (2000-5000)	217		217	NACE/Lo-temp (2000-5000)
				2	WE/WE	22A	Extension square Nut/Mtg/Flg	222		222	NACE/Hi-temp (150-600)	222		222	NACE/Hi-temp (150-600)
				3	RF/WE	23	Worm gear with 2 inch square operating nut	259		259	NACE/316 Inlay (150-2500)	259		259	NACE/316 Inlay (150-2500)
				4	RTJ/RTJ	23A	Worm gear with right angle pinion shaft extension and 2 in. square operating nut								
				5	RTJ/WE										
				9	All Others										

## CAMERON FULLY WELDED BALL VALVES STANDARDS, SPECIFICATIONS AND MATERIALS

CAMERON fully welded ball valves conform to one or more of the following specifications for pressure, temperature ratings and dimensions: ASME/ANSI, ISO 14313/API 6D, ISO 10423/API 6A, ISO 14723/API 6DSS, DIN, AFNOR, British standards, ISO 9000 and API Q1.

### Trim Materials for Standard Valves

Pressure range	ASME/ANSI Class 150-2500 (PN 20-PN 420)
Temperature range	-20° F to 250° F (-29° C to 121° C)
Body	ASTM A350 Gr. LF-2(M)
End connection	ASTM A350 Gr. LF-2(M)
Ball	ASTM A694 Gr. F50(M) Chrome plated or ENP
Seat ring	AISI 1040
Seat load spring	AISI 1040
Stem seals	PTFE
Lip seals	PTFE
Seat ring insert	Nylon

Other trims are available upon request.

### Optional Trim Materials

Trim	Pressure Rating	Temperature Rating	TRIM NUMBERS	
			Regular	Corrosion Resistant (NACE MR0175)
Standard	ASME/ANSI Class 150 - 2500	-20°F to 250°F (-29°C to 121°C)	1	212
	API 2000-5000	-20°F to 250°F (-29°C to 121°C)	2	213
Low temperature	ASME/ANSI Class 150 - 2500	-50°F to 250°F (-46°C to 121°C)	8	216
	API 2000-5000	-50°F to 250°F (-46°C to 121°C)	-	217
High temperature	ASME/ANSI Class 150 - 600	-20°F to 375°F (-29°C to 190°C)	4	222
Tefzel	ASME/ANSI Class 150 - 1500	-20°F to 300°F (-29°C to 149°C)	140	214
(Acidizing)	API 2000-5000	-20°F to 300°F (-29°C to 149°C)	108	215
Tefzel	ASME/ANSI Class 150 - 1500	-50°F to 300°F (-46°C to 149°C)	223	-
Low temperature	API 2000-5000	-50°F to 300°F (-46°C to 149°C)	-	-
Duplex (Internal) stainless steel	ASME/ANSI Class 150 - 1500	-20°F to 250°F (-29°C to 121°C)	-	276
Full duplex stainless steel	ASME/ANSI Class 150 - 1500	-50°F to 250°F (-46°C to 121°C)	-	504

### Materials

Materials used in ball valve construction are broadly equivalent at all Cameron's Valves & Measurement group manufacturing plants. However, the availability of local supplies, the need to conform to national standards and to offer various trims may necessitate some variations. In corrosive applications, valve trims may be offered using various types of alloys and stainless steels. For more information on material specifications and properties, please contact your local Cameron's Valves & Measurement group representative.

### Torque Information

Please contact your Cameron representative to obtain a copy of the engineering bulletin which provides detailed torque information for sizing of power actuators.

# CAMERON FULLY WELDED BALL VALVES

## STANDARDS, SPECIFICATIONS AND MATERIALS (Cont.)

### Dimensional Codes for Flanged and Weld Ends (Full and Reduced Openings)

Code Identification:

- A End to end (length dimension)
- B Bore diameter
- C Centerline to bottom
- D1 Flange outside diameter
- D2 Flange inside dimension
- E Sphere dimension

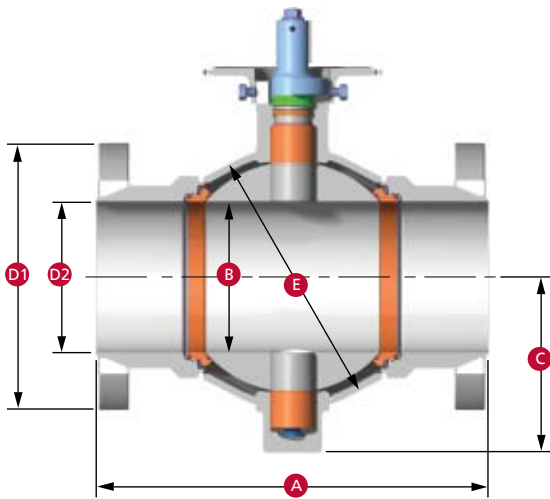

SD-24027

### Dimensional Codes for Cameron Manual Operators

Code Identification:

- G Handwheel diameter
- H Center of bore to top of square nut for lever operated valves, center of bore to handwheel for gear operated valves
- L Center of bore to end of lever

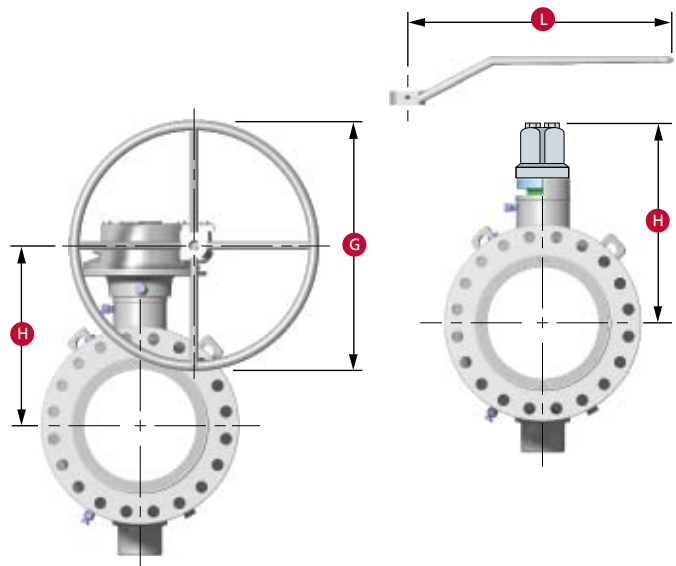

SD-24028

SD-24029

# CAMERON FULLY WELDED BALL VALVES

## FULL BORE ASME / ANSI CLASS 150 (PN 20)

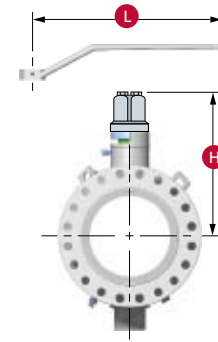
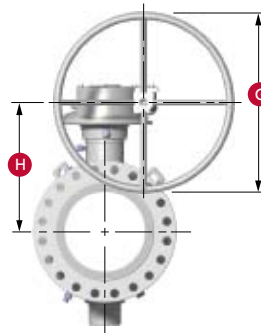
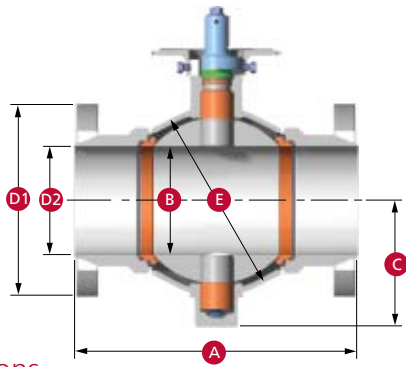

### Dimensions

SIZE in.		Flanged End ■					Weld End ■	C.L. to Bottom	Body Sphere	Lever Length	Diameter Handwheel for Gear	C.L. to Handwheel C.L.	Approximate Valve Weight lb.	
Nom Dia.	Ball Bore B	Stem Size	RF Length A	RTJ Length A	Dia. D1*	Dia. D2	A	C	E	L	G	H	Flange	Weld
2	2.06	1.0	7.0	7.5	6.00	2.06	11.0♦	3.94	5.00	24	-	6.34	39	45
3	3.13	1.0	8.0	8.5	7.50	3.13	12.5♦	5.12	6.75	24	-	7.44	62	75
4	4.06	1.5	9.0	9.5	9.00	4.06	14.0	5.94	8.50	36	-	8.43	115	100
6	6.00	1.5	15.5	16.0	11.00	6.00	18.0	7.91	11.25	-	12	10.43	200	225
8	8.00	2.0	18.0	18.5	13.50	8.00	21.5♦	10.00	15.50	-	18	12.55	428	450
10	10.00	2.0	21.0	21.5	16.00	10.00	23.5♦	12.12	18.50	-	18	14.54	705	650
12	12.00	3.0	24.0	24.5	19.00	12.00	26.5♦	14.50	22.36	-	18	20.14	1210	1100
14	13.25	3.0	27.0	27.5	21.00	13.25	28.5*	14.64	24.00	-	18	21.16	1330	1230
16	15.25	3.0	30.0	30.5	23.50	15.25	30.5*	16.01	26.32	-	18	22.52	1650	1550
18	17.25	4.0	34.0	34.5	25.00	17.25	33.5*	19.25	29.20	-	24	26.19	2325	2200
20	19.25	4.0	36.0	36.5	27.50	19.25	35.5*	20.81	32.27	-	18	27.75	3310	2760
22	21.25	4.0	40.0	40.5	29.50	21.25	38.5*	22.28	36.00	-	18	29.22	3875	3510
24	23.25	4.0	42.0	42.5	32.00	23.25	42.0*	23.69	38.76	-	18	30.63	4620	4260
26	25.00	5.0	45.0	-	34.25	25.00	44.5*	26.49	41.75	-	24	34.34	6400	5600
28	27.00	5.0	49.0	-	36.50	27.00	47.0*	27.88	44.86	-	24	35.72	7200	6500
30	29.00	5.0	51.0	-	38.75	29.00	49.0*	29.51	47.90	-	24	37.37	9500	8800
34	32.75	5.0	58.0	-	43.75	32.75	54.5*	32.16	53.64	-	30	40.01	13500	12000
36	34.50	5.0	60.0	-	46.00	34.50	56.5*	33.76	56.83	-	36	41.60	15150	14500
40	38.50	7.5	69.0	-	50.75	38.50	65.0*	40.14	65.00	-	30	50.25	-	-
42	41.25	7.5	72.0	-	53.00	41.25	66.5*	41.78	68.60	-	42	51.89	-	-
48	46.50	7.5	80.0	-	59.50	46.50	76.0*	45.90	77.00	-	-	-	-	-
SIZE mm														kg
50	52	25	178	191	152	52	279♦	100	127	610	-	161	18	20
80	80	25	203	216	191	80	318♦	130	171	610	-	189	28	34
100	103	38	229	241	229	103	356	151	216	914	-	214	52	45
150	152	38	394	406	279	152	457	201	286	-	305	265	91	102
200	203	51	457	470	343	203	546♦	254	394	-	457	319	194	204
250	254	51	533	546	406	254	597♦	308	470	-	457	369	320	295
300	305	76	610	622	483	305	673♦	368	568	-	457	512	549	499
350	337	76	686	699	533	337	724*	372	610	-	457	537	603	558
400	387	76	762	775	597	387	775*	407	669	-	457	572	748	703
450	438	102	864	876	635	438	851	489	742	-	610	665	1055	998
500	489	102	914	927	699	489	902	529	820	-	457	705	1501	1252
550	540	102	1016	1029	749	540	978*	566	914	-	457	742	1758	1592
600	591	102	1067	1080	813	591	1067*	602	985	-	457	778	2096	1932
650	635	127	1143	-	870	635	1130*	673	1060	-	610	872	2903	2540
700	686	127	1245	-	927	686	1194*	708	1139	-	610	907	3266	2948
750	737	127	1295	-	984	737	1245*	750	1217	-	610	949	4309	3992
850	832	127	1473	-	1111	832	1384*	817	1362	-	762	1016	6123	5443
900	876	127	1524	-	1168	876	1435*	858	1443	-	914	1057	6872	6577
1000	978	191	1753	-	1289	978	1651*	1020	1651	-	762	1276	-	-
1050	1048	191	1829	-	1346	1048	1689*	1061	1742	-	1067	1318	-	-
1200	1181	191	2032	-	1511	1181	1930*	1166	1956	-	-	-	-	-

■ Length (A) of a weld x flanged end valve is one half the sum of length (A) of a weld end and a flange end of the same size and rating.  
 \* Short pattern.  
 ♦ Length exceeds specified dimensions in API 6D/ISO 14313.  
 • Dimensions of 22 in. (550 mm) flanges are per MSS-SP-44 and 26 in. (650 mm) through 42 in. (1050 mm) flanges are per ASME B16.47 series A.

# CAMERON FULLY WELDED BALL VALVES

## REDUCED BORE ASME / ANSI CLASS 150 (PN 20)

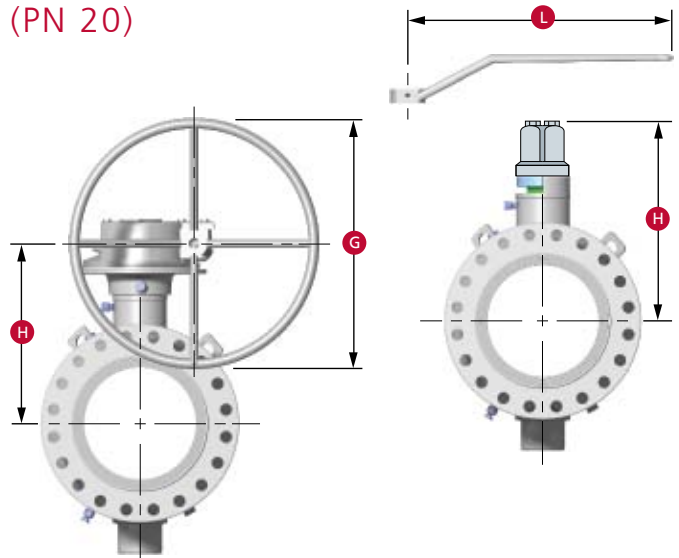
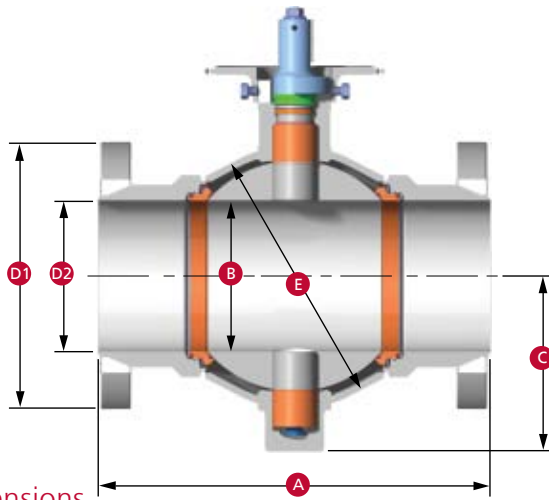
**Dimensions**

SIZE in.	Ball Bore	Stem Size	Flanged End ■		Weld End ■	C.L. to Bottom	Body Sphere	Lever Length	Diameter Handwheel for Gear	C.L. to Handwheel C.L.	Approximate Valve Weight lb.				
			RF Length	RTJ Length							Flange	Weld			
Nom Dia.	B		A	A	A	C	E	L	G	H					
3	2.06	1.0	8.0	8.5	7.50	3.13	11.0♦	3.94	5.00	24	-	6.34	55	50	
4	3.13	1.0	9.0	9.5	9.00	4.06	12.5♦	5.12	6.75	24	-	7.44	100	87	
6	4.06	1.5	15.5	16.0	11.00	6.00	14.0♦	5.94	8.50	36	-	8.43	170	150	
8	6.00	1.5	18.0	18.5	13.50	8.00	18.0	7.91	11.25	-	12	10.43	345	290	
10	8.00	2.0	21.0	21.5	16.00	10.00	21.5♦	10.00	15.50	-	18	12.55	620	525	
12	10.00	2.0	24.0	24.5	19.00	12.00	23.5♦	12.12	18.50	-	18	14.54	950	840	
14	12.00	3.0	27.0	27.5	21.00	13.25	26.5♦	14.50	22.36	-	18	20.14	1280	1160	
16	13.25	3.0	30.0	30.5	23.50	15.25	28.5*	14.64	24.00	-	18	21.16	1450	1330	
18	15.25	3.0	34.0	34.5	25.00	17.25	30.5*	16.01	26.32	-	18	22.52	1510	1700	
20	17.25	4.0	36.0	36.5	27.50	19.25	33.5*	19.25	29.20	-	24	26.19	2410	2300	
22	19.25	4.0	40.0	40.5	29.50	21.25	35.5*	20.81	32.27	-	18	27.75	3450	3050	
24	21.25	4.0	42.0	42.5	32.00	23.25	38.5*	22.28	36.00	-	18	29.22	4300	3650	
26	23.25	4.0	45.0	-	34.25	25.00	42.0*	23.69	38.76	-	18	30.63	5400	5100	
28	25.00	5.0	49.0	-	36.50	27.00	44.5*	26.49	41.75	-	24	34.34	7040	6100	
30	27.00	5.0	51.0	-	38.75	29.00	47.0*	27.88	44.86	-	24	35.72	8900	7600	
32	29.00	5.0	54.0	-	41.75	32.75	49.0*	29.51	47.90	-	24	37.37	9600	8500	
36	32.75	5.0	60.0	-	46.00	34.50	54.5*	32.16	53.64	-	30	40.01	14000	12500	
42	34.50	5.0	72.0	-	53.00	41.25	56.5*	33.76	56.83	-	36	41.60	-	-	
SIZE mm															kg
80	52	25	203	216	191	80	279♦	100	127	610	-	161	25	23	
100	80	25	229	241	229	103	318♦	130	172	610	-	189	45	39	
150	103	38	394	406	279	152	356♦	151	216	914	-	214	77	68	
200	152	38	457	470	343	203	457	201	286	-	305	265	156	132	
250	203	51	533	546	406	254	564♦	254	394	-	457	319	281	238	
300	254	51	610	622	483	305	597♦	308	470	-	457	369	431	381	
350	305	76	686	699	533	337	673♦	368	568	-	457	512	581	526	
400	337	76	762	775	597	387	724*	372	610	-	457	537	658	603	
450	387	76	864	876	635	438	774*	407	669	-	457	572	685	771	
500	438	102	914	927	699	489	851*	489	741	-	610	665	1093	1043	
550	489	102	1016	1029	749	540	902*	529	820	-	457	705	1565	1383	
600	540	102	1067	1080	813	591	978*	566	914	-	457	742	1950	1656	
650	591	102	1143	-	870	635	1067*	602	985	-	457	778	2449	2313	
700	635	127	1245	-	927	686	1130*	673	1061	-	610	872	3193	2767	
750	686	127	1295	-	984	737	1194*	708	1139	-	610	907	4037	3447	
800	737	127	1372	-	1048	832	1245*	750	1217	-	610	949	4355	3856	
900	832	127	1524	-	1168	876	1384*	817	1363	-	762	1016	6350	5670	
1050	876	127	1829	-	1346	1048	1435*	858	1444	-	914	1057	-	-	

■ Length (A) of a weld x flanged end valve is one half the sum of length (A) of a weld end and a flange end of the same size and rating.  
 \* Short pattern.  
 ♦ Length exceeds specified dimensions in API 6D/ISO 14313.  
 • Dimensions of 22 in. (550 mm) flanges are per MSS-SP-44 and 26 in. (650 mm) through 42 in. (1050 mm) flanges are per ASME B16.47 series A.  
 Note: Venturi opening or other reduced bore valves are available upon request.



# CAMERON FULLY WELDED BALL VALVES

## FULL BORE ASME / ANSI CLASS 300 (PN 50)

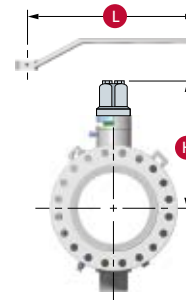
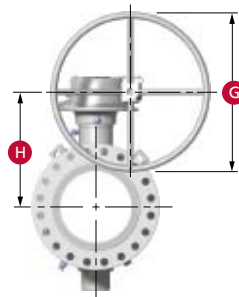
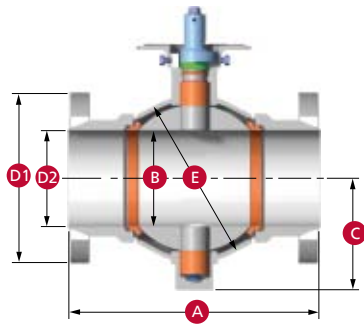

### Dimensions

SIZE in.		Ball Bore B	Stem Size	Flanged End ■		Weld End ■ Length A	C.L. to Bottom C	Body Sphere E	Lever Length L	Diameter Handwheel for Gear G	C.L. to Handwheel C.L. H	Approximate Valve Weight lb.		
Nom Dia.	RF Length A			RTJ Length A	Dia. D1°							Dia. D2	Flange	Weld
2	2.06	1.0	8.50	9.125	6.50	2.06	11.0♦	3.94	5.00	24	-	6.34	50	45
3	3.13	1.0	11.125	11.750	8.25	3.13	12.5♦	5.12	6.75	24	-	7.44	80	75
4	4.06	1.5	12.00	12.625	10.00	4.06	14.0♦	5.94	8.50	36	-	8.43	125	100
6	6.00	1.5	15.875	16.500	12.50	6.00	18.0	7.91	11.25	-	12	10.43	250	225
8	8.00	2.0	19.75**	20.375	15.00	8.00	21.5♦	10.00	15.50	-	18	12.55	455	450
10	10.00	2.0	22.375	23.000	17.50	10.00	23.5♦	12.12	18.50	-	18	14.54	750	650
12	12.00	3.0	25.50	26.125	20.50	12.00	26.5♦	14.50	22.36	-	18	20.14	1275	1100
14	13.25	3.0	30.00	30.625	23.00	13.25	28.5*	14.64	24.00	-	24	21.16	1370	1230
16	15.25	3.0	33.00	33.625	25.50	15.25	30.5*	16.01	26.32	-	24	22.52	1725	1550
18	17.25	4.0	36.00	36.625	28.00	17.25	33.5*	19.25	29.20	-	24	26.19	2700	2200
20	19.25	4.0	39.00	39.750	30.50	19.25	35.5*	20.81	32.27	-	18	27.75	3400	2760
22	21.25	4.0	43.00	43.875	33.00	21.25	38.5*	22.28	36.00	-	24	29.22	4050	3510
24	23.25	4.0	45.00	45.875	36.00	23.25	42.0*	23.69	38.76	-	24	30.63	5390	4260
26	25.00	5.0	49.00	50.000	38.25	25.00	44.5*	26.49	41.75	-	24	34.34	6625	5600
28	27.00	5.0	53.00	54.000	40.75	27.00	47.0*	27.88	44.86	-	24	35.72	7725	6500
30	29.00	5.0	55.00	56.000	43.00	29.00	49.0*	29.51	47.90	-	30	37.37	10000	8800
34	32.75	5.0	64.00	65.125	47.50	32.75	54.5*	32.16	53.64	-	36	40.01	14700	12000
36	34.50	7.5	68.00	69.125	50.00	34.50	56.5*	36.80	56.83	-	24	46.92	16300	15500
40	38.50	7.5	74.00	-	48.75	38.50	65.0*	40.14	65.00	-	36	50.25	-	-
42	41.25	7.5	76.00	-	50.75	41.25	66.5*	41.78	68.60	-	42	51.89	-	-
48	46.50	7.5	86.00	-	57.75	46.50	76.0*	45.90	77.00	-	-	-	-	-

SIZE mm														kg
50	52	25	216	232	165	52	279♦	100	127	610	-	161	23	20
80	80	25	283	298	210	80	318♦	130	172	610	-	189	36	34
100	103	38	305	321	254	103	356♦	151	216	914	-	214	57	45
150	152	38	403	419	318	152	457	201	286	-	305	265	113	102
200	203	51	502**	518	381	203	546♦	254	394	-	457	319	206	204
250	254	51	568	584	445	254	597♦	308	470	-	610	369	340	295
300	305	76	648	664	521	305	673♦	368	568	-	457	512	578	499
350	337	76	762	778	584	337	724*	372	610	-	610	537	621	558
400	387	76	838	854	648	387	775*	407	669	-	610	572	782	703
450	438	102	914	930	711	438	851*	489	742	-	610	665	1225	998
500	489	102	991	1010	775	489	902*	529	820	-	457	705	1542	1252
550	540	102	1092	1114	838	540	978*	566	914	-	610	742	1837	1592
600	591	102	1143	1165	914	591	1067*	602	985	-	610	778	2445	1932
650	635	127	1245	1270	972	635	1130*	673	1060	-	610	872	3005	2540
700	686	127	1346	1372	1035	686	1194*	708	1139	-	610	907	3504	2948
750	737	127	1397	1422	1092	737	1245*	750	1217	-	762	949	4536	3992
850	832	127	1626	1654	1207	832	1384*	817	1362	-	914	1016	6668	5443
900	876	191	1727	1756	1270	876	1435*	935	1443	-	610	1192	7394	7031
1000	978	191	1880	-	1238	978	1651*	1020	1651	-	914	1276	-	-
1050	1048	191	1930	-	1289	1048	1689*	1061	1742	-	1067	1318	-	-
1200	1181	191	2184	-	1467	1181	1930*	1166	1956	-	-	-	-	-

- Length (A) of a weld x flanged end valve is one half the sum of length (A) of a weld end and a flanged end of the same size and rating.
- \* Short pattern.
- ♦ Length exceeds specified dimensions in API 6D/ISO 14313.
- Dimensions of 22 in. (550 mm) flanges are per MSS-SP-44 and 26 in. (650 mm) through 42 in. (1050 mm) flanges are per ASME B16.47 series A.
- \*\* Prior to 1/1/98 - manufactured to 16.5 in. (419 mm) short pattern length.

# CAMERON FULLY WELDED BALL VALVES

## REDUCED BORE ASME / ANSI CLASS 300 (PN 50)

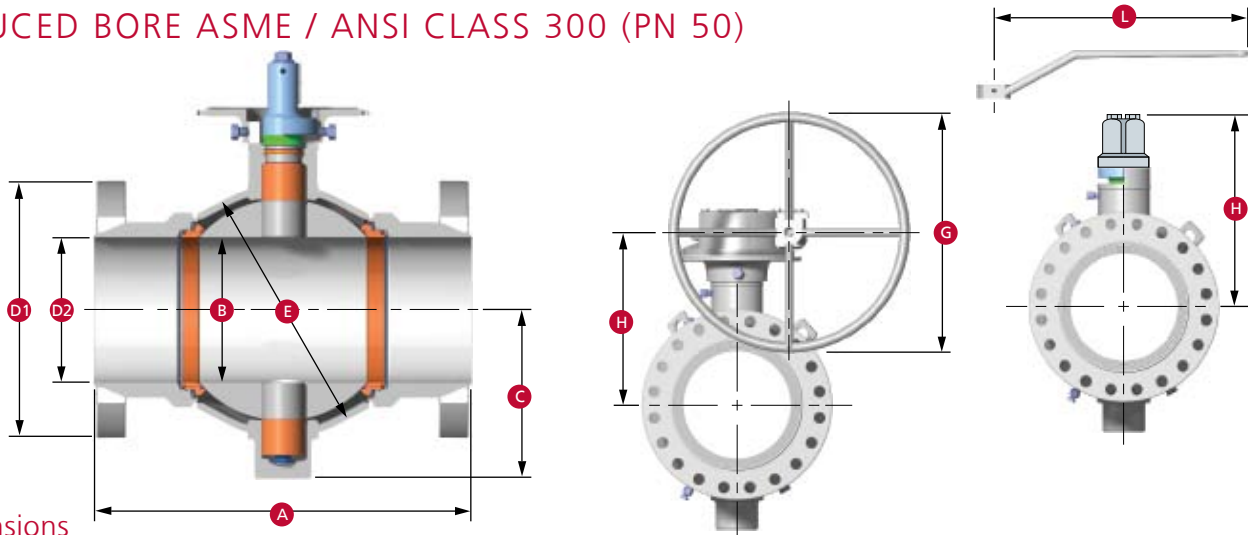
**Dimensions**

SIZE in.	Ball Bore		Flanged End		Weld End	C.L. to Bottom	Body Sphere	Lever Length	Diameter Handwheel for Gear	C.L. to Handwheel C.L.	Approximate Valve Weight lb.			
Nom Dia.	B	Stem Size	RF Length A	RTJ Length A	Dia. D1*	Dia. D2	Length A	C	E	L	G	H	Flange	Weld
3	2.06	1.0	11.125	11.75	8.25	3.13	11.0*	3.94	5.00	24	-	6.34	64	50
4	3.13	1.0	12.00	12.625	10.00	4.06	12.5♦	5.12	6.75	24	-	7.44	95	87
6	4.06	1.5	15.875	16.500	12.50	6.00	14.0*	5.94	8.50	36	-	8.43	180	150
8	6.00	1.5	19.75**	20.375	15.00	8.00	18.0*	7.91	11.25	-	12	10.43	365	290
10	8.00	2.0	22.375	23.000	17.50	10.00	21.5*	10.00	15.50	-	18	12.55	650	525
12	10.00	2.0	25.50	26.125	20.50	12.00	23.5*	12.12	18.50	-	18	14.54	1050	840
14	12.00	3.0	30.00	30.625	23.00	13.25	26.5*	14.50	22.36	-	18	20.14	1285	1160
16	13.25	3.0	33.00	33.625	25.50	15.25	28.5*	14.64	24.00	-	24	21.16	1660	1330
18	15.25	3.0	36.00	36.625	28.00	17.25	30.5*	16.01	26.32	-	24	22.52	1990	1700
20	17.25	4.0	39.00	39.750	30.50	19.25	33.5*	19.25	29.20	-	24	26.19	3100	2300
22	19.25	4.0	43.00	43.875	33.00	21.25	33.5*	20.81	32.27	-	18	27.75	3600	3050
24	21.25	4.0	45.00	45.875	36.00	23.25	38.5*	22.28	36.00	-	24	29.22	4500	3650
26	23.25	4.0	49.00	50.000	38.25	25.00	42.0*	23.69	38.76	-	24	30.63	5750	5100
28	25.00	5.0	53.00	54.000	40.75	27.00	44.5*	26.49	41.75	-	24	34.34	7260	6100
30	27.00	5.0	55.00	56.000	43.00	29.00	47.0*	27.88	44.86	-	24	35.72	9100	7600
32	29.00	5.0	60.00	61.125	45.25	32.75	49.0*	29.51	47.90	-	30	37.37	10150	8800
36	32.75	5.0	68.00	69.125	50.00	34.50	54.5*	32.16	53.64	-	36	40.01	15350	13000
42	34.50	7.5	76.00	-	50.75	41.25	56.5*	36.80	56.83	-	24	49.92	-	-
SIZE mm	kg													
80	52	25	283	298	210	80	279*	100	127	610	-	161	29	23
100	80	25	305	321	254	103	318♦	130	171	610	-	189	43	39
150	103	38	403	419	318	152	356*	151	216	914	-	214	82	68
200	152	38	502**	518	381	203	457*	201	286	-	305	265	166	132
250	203	51	568	584	445	254	546*	254	394	-	457	319	295	238
300	254	51	648	664	521	305	597*	308	470	-	457	369	476	381
350	305	76	762	778	584	337	673*	368	568	-	457	512	583	526
400	337	76	838	854	648	387	724*	372	610	-	610	537	753	603
450	387	76	914	930	711	438	775*	407	669	-	610	572	903	771
500	438	102	991	1010	775	489	851*	489	742	-	610	665	1406	1043
550	489	102	1092	1114	838	540	851*	529	820	-	457	705	1633	1383
600	540	102	1143	1165	914	591	978*	566	914	-	610	742	2041	1656
650	591	102	1245	1270	972	635	1067*	602	985	-	610	778	2608	2313
700	635	127	1346	1372	1035	686	1130*	673	1060	-	610	872	3293	2767
750	686	127	1397	1422	1092	737	1194*	708	1139	-	610	907	4128	3447
800	737	127	1524	1553	1149	832	1245*	750	1217	-	762	949	4604	3992
900	832	127	1727	1756	1270	867	1384*	817	1362	-	914	1016	6963	5897
1050	876	191	1930	-	1289	1048	1435*	935	1443	-	610	1192	-	-

■ Length (A) of a weld x flanged end valve is one half the sum of length (A) of a weld end and a flange end of the same size and rating.

\* Short pattern.

♦ Length exceeds specified dimensions in API 6D/ISO 14313.

• Dimensions of 22 in. (550 mm) flanges are per MSS-SP-44 and 26 in. (650 mm) through 42 in. (1050 mm) flanges are per ASME B16.47 series A.

\*\* Prior to 1/1/98 - manufactured to 16.5 in. (419 mm) short pattern length.

Note: Venturi opening or other reduced bore valves are available upon request.

# CAMERON FULLY WELDED BALL VALVES

## FULL BORE ASME/ANSI CLASS 400 (PN 64)

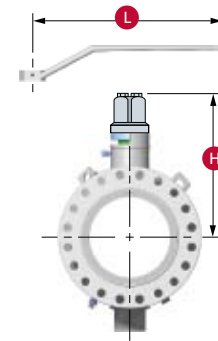
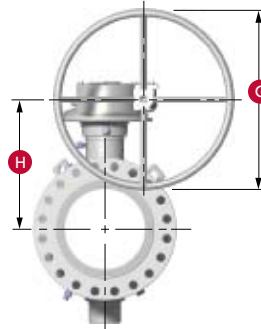
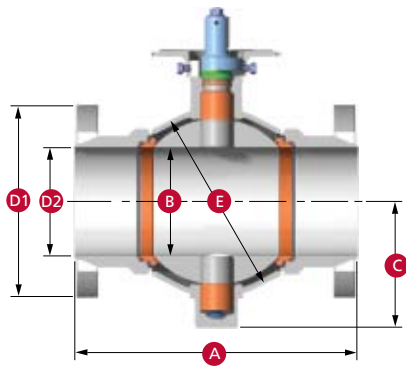

### Dimensions

SIZE in.		Flanged End ■						Weld End ■	C.L. to Bottom	Body Sphere	Lever Length	Diameter Handwheel for Gear	C.L. to Handwheel C.L.	Approximate Valve Weight lb.	
Nom Dia.	Ball Bore B	Stem Size	RF Length A	RTJ Length A	Dia. D1*	Dia. D2	A	C	E	L	G	H	Flange	Weld	
2	2.06	Use ASME/ANSI Class 600 Valves (PN 100)													
3	3.13	Use ASME/ANSI Class 600 Valves (PN 100)													
4	4.06	1.5	16.0	16.125	10.00	4.06	14.0*	5.94	8.50	48	-	8.43	150	100	
6	6.00	1.5	19.5	19.625	12.50	6.00	18.0*	7.91	11.25	-	12	10.43	300	225	
8	8.00	2.0	23.5	23.625	15.00	8.00	21.5*	10.00	15.50	-	18	12.55	550	450	
10	10.00	2.0	26.5	26.625	17.50	10.00	23.5*	12.12	18.50	-	24	14.54	850	650	
12	12.00	3.0	30.0	30.125	20.50	12.00	26.5*	14.50	22.36	-	18	20.14	1400	1100	
14	13.25	3.0	32.5	32.625	23.00	13.25	28.5*	14.64	24.00	-	24	21.16	1650	1230	
16	15.25	4.0	35.5	35.625	25.50	15.25	30.5*	17.84	26.32	-	18	24.78	2225	1770	
18	17.25	4.0	38.5	38.625	28.00	17.25	33.5*	19.25	29.20	-	24	26.19	2850	2200	
20	19.25	5.0	41.5	41.750	30.50	19.25	35.5*	22.11	32.27	-	24	30.00	3750	3000	
22	21.25	5.0	45.0	45.375	33.00	21.25	38.5*	23.63	36.00	-	24	31.53	4750	3950	
24	23.25	5.0	48.5	48.875	36.00	23.25	42.0*	25.05	38.76	-	24	32.95	5600	4750	
26	25.00	5.0	51.5	52.000	38.25	25.00	44.5*	26.49	41.75	-	24	34.34	7100	5600	
28	27.00	5.0	55.0	55.500	40.75	27.00	47.0*	27.88	44.86	-	30	35.72	8560	6500	
30	29.00	5.0	60.0	60.500	43.00	29.00	49.0*	29.51	47.90	-	36	37.37	10600	8800	
34	32.75	7.5	70.0	70.625	47.50	32.75	54.5*	35.19	53.64	-	30	45.31	15400	12300	
36	34.50	7.5	74.0	74.625	50.00	34.50	56.5*	36.80	56.83	-	30	46.92	18000	15500	
40	38.50	7.5	78.0	-	50.00	38.50	65.0*	40.14	65.00	-	42	50.25	25500	22250	
42	41.25	7.5	81.0	-	52.00	41.25	66.5*	41.78	68.60	-	42	51.89	28750	24750	
48	46.50	9.0	91.0	-	59.50	46.50	76.0*	47.98	77.00	-	-	-	-	-	

SIZE mm																kg
50	52	Use ASME/ANSI Class 600 Valves (PN 100)														
80	80	Use ASME/ANSI Class 600 Valves (PN 100)														
100	103	38	406	410	254	103	356*	151	216	1219	-	214	68	45		
150	152	38	495	498	318	152	457*	201	286	-	305	265	136	102		
200	203	51	597	600	381	203	546*	254	394	-	457	319	249	204		
250	254	51	673	676	445	254	597*	308	470	-	610	369	386	295		
300	305	76	762	765	521	305	673*	368	568	-	457	512	635	499		
350	337	76	826	829	584	337	724*	372	610	-	610	537	748	558		
400	387	102	902	905	648	387	775*	453	669	-	457	629	1009	803		
450	438	102	978	981	711	438	851*	489	742	-	610	665	1293	998		
500	489	127	1054	1060	775	489	902*	562	820	-	610	762	1701	1361		
550	540	127	1143	1153	838	540	978*	600	914	-	610	801	2155	1792		
600	591	127	1232	1241	914	591	1067*	636	985	-	610	837	2540	2155		
650	635	127	1308	1321	9712	635	1130*	673	1060	-	610	872	3221	2540		
700	686	127	1397	1410	1035	686	1194*	708	1139	-	762	907	3883	2948		
750	737	127	1524	1537	1092	737	1245*	750	1217	-	914	949	4808	3992		
850	832	191	1778	1794	1207	832	1384*	894	1362	-	762	1151	6985	5579		
900	876	191	1880	1895	1270	876	1435*	935	1443	-	762	1192	8165	7031		
1000	978	191	1981	-	1270	978	1651*	1020	1651	-	1067	1276	11567	10092		
1050	1048	191	2057	-	1321	1048	1689*	1061	1742	-	1067	1318	13041	11226		
1200	1181	229	2311	-	1511	1181	1930*	1219	1956	-	-	-	-	-		

■ Length (A) of a weld x flanged end valve is one half the sum of length (A) of a weld end and a flange end of the same size and rating.

\* Short pattern.

• Dimensions of 22 in. (550 mm) flanges are per MSS-SP-44 and 26 in. (650 mm) through 42 in. (1050 mm) flanges are per ASME B16.47 series A.

# CAMERON FULLY WELDED BALL VALVES

## REDUCED BORE ASME / ANSI CLASS 400 (PN 64)

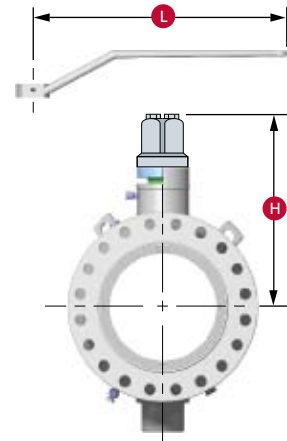
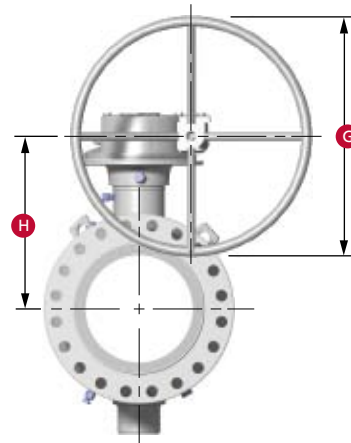
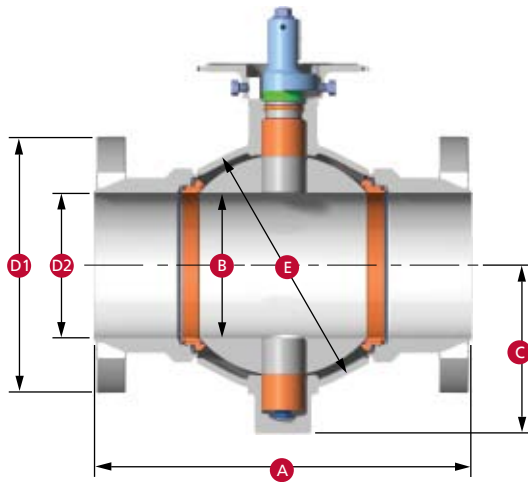

### Dimensions

SIZE in.		Stem Size	Flanged End ■		Weld End ■ Length	C.L. to Bottom	Body Sphere	Lever Length	Diameter Handwheel for Gear	C.L. to Handwheel C.L.	Approximate Valve Weight lb.			
Nom Dia.	Ball Bore B		RF Length A	RTJ Length A							Dia. D1*	Dia. D2	Flange	Weld
3	2.06	Use ASME/ANSI Class 600 Valves (PN 100)										-	-	
4	3.13	1.0	16.0	16.125	10.00	4.06	12.5*	5.12	6.75	24	-	7.44	125	87
6	4.06	1.5	19.5	19.625	12.50	6.00	14.0*	5.94	8.50	48	-	8.43	189	150
8	6.00	1.5	23.5	23.625	15.00	8.00	18.0*	7.91	11.25	-	12	10.43	424	290
10	8.00	2.0	26.5	26.625	17.50	10.00	21.5*	10.00	15.50	-	18	12.55	608	525
12	10.00	2.0	30.0	30.125	20.50	12.00	23.5*	12.12	18.50	-	24	14.54	1020	840
14	12.00	3.0	32.5	32.625	23.00	13.25	26.5*	14.50	22.36	-	18	20.14	1490	1160
16	13.25	3.0	35.5	35.625	25.25	15.25	28.5*	14.64	24.00	-	24	21.16	1910	1330
18	15.25	4.0	38.5	38.625	28.00	17.25	30.5*	17.84	36.32	-	18	24.78	2400	1920
20	17.25	4.0	41.5	41.750	30.50	19.25	33.5*	19.25	29.20	-	24	26.19	3200	2650
22	19.25	5.0	45.0	45.375	33.00	21.25	35.5*	22.11	32.27	-	24	30.00	4250	3300
24	21.25	5.0	48.5	48.875	36.00	23.25	38.5*	23.63	36.00	-	24	31.53	5050	4300
26	23.25	5.0	51.5	52.000	38.25	25.00	42.0*	25.05	38.76	-	24	32.95	6250	5100
28	25.00	5.0	55.0	55.500	40.75	27.00	44.5*	26.49	41.75	-	24	34.34	7750	6100
30	27.00	5.0	60.0	60.500	43.00	29.00	47.0*	27.88	44.86	-	30	35.72	9500	7600
32	29.00	5.0	65.0	65.625	45.25	32.75	49.0*	29.51	47.90	-	36	37.37	11500	9350
36	32.75	7.5	74.0	74.625	50.00	34.50	54.5*	35.19	53.64	-	30	45.31	16000	13000
42	34.50	7.5	81.0	-	52.00	41.25	56.5*	36.80	56.83	-	30	46.92	-	-
SIZE mm												kg		
80	52	Use ASME/ANSI Class 600 Valves (PN 100)										-	-	
100	80	25	406	410	254	103	318*	130	171	610	-	189	57	39
150	103	38	495	498	318	152	356*	151	216	1219	-	214	86	68
200	152	38	597	600	381	203	457*	201	286	-	305	265	192	132
250	203	51	673	676	445	254	546*	254	394	-	457	319	276	238
300	254	51	762	765	521	305	597*	308	470	-	610	369	463	381
350	305	76	826	829	584	337	673*	368	568	-	457	512	676	526
400	337	76	902	905	641	387	724*	372	610	-	610	537	866	603
450	387	102	978	981	711	438	775*	453	923	-	457	629	1089	871
500	438	102	1054	1060	775	489	851*	489	742	-	610	665	1451	1202
550	489	127	1143	1153	838	540	902*	562	820	-	610	762	1928	1497
600	540	127	1232	1241	914	591	978*	600	914	-	610	801	2291	1950
650	591	127	1308	1321	972	635	1067*	636	985	-	610	837	2835	2313
700	635	127	1397	1410	1035	686	1130*	673	1060	-	610	872	3515	2767
750	686	127	1524	1537	1092	737	1194*	708	1139	-	762	907	4309	3447
800	737	127	1651	1667	1149	832	1245*	750	1217	-	914	949	5216	4241
900	832	191	1880	1895	1270	876	1384*	894	1362	-	762	1151	7257	5897
1050	876	191	2057	-	1321	1048	1435*	935	1443	-	762	1192	-	-

- Length (A) of a weld x flanged end valve is one half the sum of length (A) of a weld end and a flange end of the same size and rating.
  - \* Short pattern.
  - Dimensions of 22 in. (550 mm) flanges are per MSS-SP-44 and 26 in. (650 mm) through 42 in. (1050 mm) flanges are per ASME B16.47 series A.
- Note: Venturi opening or other reduced bore valves are available upon request.

# CAMERON FULLY WELDED BALL VALVES

## FULL BORE ASME / ANSI CLASS 600 (PN 100)

Please use illustrations from next page as a reference.

### Dimensions

SIZE in.														
Nom Dia.	Ball Bore B	Stem Size	Flanged End ■		Weld End ■ Length A	C.L. to Bottom C	Body Sphere E	Lever Length L	Diameter Handwheel for Gear G	C.L. to Handwheel C.L. H	Approximate Valve Weight lb.			
			RF Length A	RTJ Length A							Dia. D1*	Dia. D2	Flange	Weld
2	2.06	1	11.5	11.625	6.5	2.06	11.0*	3.94	5	24	-	6.34	60	45
3	3.13	1	14	14.125	8.25	3.13	12.5*	5.12	6.75	36	-	7.44	85	75
4	4.06	1.5	17	17.125	10.75	4.06	14.0*	5.94	8.5	48	-	8.43	165	100
6	6.00	1.5	22	22.125	14	6	18.0*	7.91	11.25	-	12	10.43	360	225
8	8.00	2	26	26.125	16.5	8	21.5*	10	15.5	-	18	12.55	650	450
10	10.00	2	31	31.125	20	10	23.5*	12.12	18.5	-	24	14.54	1000	650
12	12.00	3	33	33.125	22	12	26.5*	14.5	22.36	-	18	20.14	1510	1100
14	13.25	3	35	35.125	23.75	13.25	28.5*	14.64	24	-	24	21.16	1910	1230
16	15.25	4	39	39.125	27	15.25	30.5*	17.84	26.32	-	18	24.78	2400	1770
18	17.25	4	43	43.125	29.25	17.25	33.5*	19.25	29.2	-	24	26.19	2955	2200
20	19.25	5	47	47.25	32	19.25	35.5*	22.11	32.27	-	24	30	4100	3000
22	21.25	5	51	51.375	34.25	21.25	38.5*	23.63	36	-	24	31.53	5400	3950
24	23.25	5	55	55.375	37	23.25	42.0*	25.05	38.76	-	30	32.95	6550	4750
26	25.00	5	57	57.5	40	25	44.5*	26.49	41.75	-	36	34.34	7800	5600
28	27.00	7.5	61	61.5	42.25	27	47.0*	30.87	44.86	-	30	40.99	9500	6700
30	29.00	7.5	65	65.5	44.5	29	49.0*	32.53	47.9	-	30	42.65	12000	9120
32	30.75	7.5	70	70.630	47.00	30.75	52.0*	34.25	52.25	-	42	44.50	13999	10494
34	32.75	7.5	76	76.625	49	32.75	54.5*	35.19	53.64	-	42	45.31	16025	12300
36	34.5	7.5	82	82.625	51.75	34.5	56.5*	36.8	56.83	-	42	46.92	19100	15500
40	38.5	9	80	-	52	38.5	65.0*	42.02	65	-	42	55.425	26770	23000
42	41.25	9	83	-	55.25	41.25	66.5*	43.66	68.6	-	42	57.06	30500	25500
44	42.75	11	-	-	-	42.75	70.5*	46.95	71.00	-	-	-	-	-
48	46.50	11	94	-	62.75	46.5	76.0*	51.18	77.33	-	-	-	-	-
56	55.12	13	-	-	-	55.12	93.7*	59.10	91.70	-	-	-	-	-
SIZE mm														
kg														
50	52	25	292	295	165	52	279*	100	127	610	-	161	27	20
80	80	25	356	359	210	80	318*	130	171	914	-	189	39	34
100	103	38	432	435	273	103	356*	151	216	1219	-	214	75	45
150	152	38	559	562	356	152	457*	201	286	-	305	265	163	102
200	203	51	660	664	419	203	546*	254	394	-	457	319	295	204
250	254	51	787	791	508	254	597*	308	470	-	610	369	454	295
300	305	76	838	841	559	304	673*	368	568	-	457	512	685	499
350	337	76	889	892	603	337	724*	372	610	-	610	537	866	558
400	387	102	991	994	686	387	775*	453	669	-	457	629	1089	803
450	438	102	1092	1095	743	438	851*	489	742	-	610	665	1340	998
500	489	127	1194	1200	813	489	902*	562	820	-	610	762	1860	1361
550	540	127	1295	1305	870	540	978*	600	914	-	610	801	2449	1792
600	591	127	1397	1407	940	591	1067*	636	985	-	762	837	2971	2155
650	635	127	1448	1461	1016	635	1130*	673	1060	-	914	872	3538	2540
700	686	191	1549	1562	1073	686	1194*	784	1139	-	762	1041	4309	3039
750	737	191	1651	1664	1130	737	1245*	826	1217	-	762	1083	5443	4137
800	781	191	1778	1794	1193.8	781	1321*	870	1327	-	1067	1130	6350	4760
850	832	191	1930	1946	1245	832	1384*	894	1362	-	1067	1151	7269	5579
900	876	191	2083	2099	1314	876	1435*	935	1443	-	1067	1192	8664	7031
1000	978	229	2032	-	1321	978	1651*	1067	1651	-	1067	1408	12143	10433
1050	1048	229	2108	-	1403	1048	1689*	1109	1742	-	1067	1449	13835	11567
1100	1086	279	-	-	-	1086	1791*	1192	1803	-	-	-	-	-
1200	1181	279	2388	-	1594	1181	1930*	1300	1964	-	-	-	-	-
1400	1400	330	-	-	-	1400	2381*	1501	2328	-	-	-	-	-

- Length (A) of a weld x flanged end valve is one half the sum of length (A) of a weld end and a flange end of the same size and rating.
- \* Short pattern.
- Dimensions of 22 in. (550 mm) flanges are per MSS-SP-44 and 26 in. (650 mm) through 42 in. (1050 mm) flanges are per ASME B16.47 series A.

# CAMERON FULLY WELDED BALL VALVES

## REDUCED BORE ASME / ANSI CLASS 600 (PN 100)

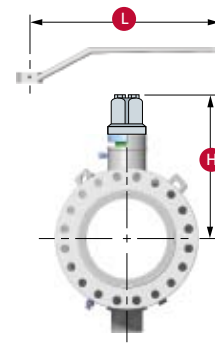
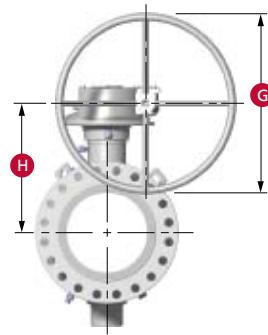
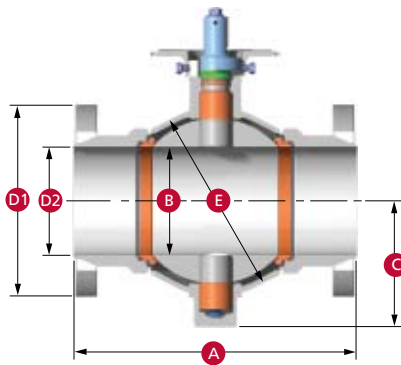

### Dimensions

SIZE in.		Ball Bore B	Stem Size	Flanged End ■		Weld End ■ Length A	C.L. to Bottom C	Body Sphere E	Lever Length L	Diameter Handwheel for Gear G	C.L. to Handwheel C.L. H	Approximate Valve Weight lb.		
Nom Dia.	RF Length A			RTJ Length A	Dia. D11*							Dia. D2	Flange	Weld
3	2.06	1	14	14.125	8.25	3.13	11.0*	3.94	5	24	-	6.34	80	50
4	3.13	1	17	17.125	10.75	4.06	12.5*	5.12	6.75	36	-	7.44	150	87
6	4.06	1.5	22	22.125	14	6	14.0*	5.94	8.5	48	-	8.43	250	150
8	6.00	1.5	26	26.125	16.5	8	18.0*	7.91	11.25	-	12	10.43	470	290
10	8.00	2	31	31.125	20	10	21.5*	10	15.5	-	18	12.55	850	525
12	10.00	2	33	33.125	22	12	23.5*	12.12	18.5	-	24	14.54	1150	840
14	12.00	3	35	35.125	23.75	13.25	26.5*	14.5	22.36	-	18	20.14	1640	1160
16	13.25	3	39	39.125	27	15.25	28.5*	14.64	24	-	24	21.16	2225	1330
18	15.25	4	43	43.125	29.25	17.25	30.5*	17.84	26.32	-	18	24.78	2600	1920
20	17.25	4	47	47.25	32	19.25	33.5*	19.25	29.2	-	24	26.19	3500	2650
22	19.25	5	51	51.375	34.25	21.25	35.5*	22.11	32.27	-	24	30	4450	3300
24	21.25	5	55	55.375	37	23.25	38.5*	23.63	36	-	24	31.53	5750	4300
26	23.25	5	57	57.5	40	25	42.0*	25.05	38.76	-	30	32.95	7000	5100
28	25.00	5	61	61.5	42.25	27	44.5*	26.49	41.75	-	36	34.34	8600	6300
30	27.00	7.5	65	65.5	44.5	29	47.0*	30.87	44.86	-	30	40.99	10100	7800
32	29.00	7.5	70.00	70.630	47.00	30.75	49.0*	32.53	47.90	-	30	42.65	12800	9350
34	29.00	7.5	76.00	76.625	49.00	32.75	49.0*	32.53	47.90	-	30	42.65	15200	11200
36	32.75	7.5	82	82.625	51.75	34.5	54.5*	35.19	53.64	-	42	45.31	17600	13000
42	34.50	7.5	83	-	55.25	41.25	56.5*	36.8	56.83	-	42	46.92	-	-
44	38.50	9	-	-	-	42.75	65.0*	42.02	65.00	-	-	-	-	-
56	46.50	11	-	-	-	55.10	76.0*	51.18	77.32	-	-	-	-	-

SIZE mm												kg		
80	52	25	356	359	210	80	279*	100	127	610	-	161	36	23
100	80	25	432	435	273	103	318*	130	171	914	-	189	68	39
150	103	38	559	562	356	152	356*	151	216	1219	-	214	113	68
200	152	38	660	664	419	203	457*	201	286	-	305	265	213	132
250	203	51	787	791	508	254	546*	254	394	-	457	319	386	238
300	254	51	838	841	559	305	597*	308	470	-	610	369	522	381
350	305	76	889	892	603	337	673*	368	568	-	457	512	744	526
400	337	76	991	994	686	387	724*	372	610	-	610	537	1009	603
450	387	102	1092	1095	743	438	775*	453	669	-	457	629	1179	871
500	438	102	1194	1200	813	489	851*	489	742	-	610	665	1588	1202
550	489	127	1295	1305	870	540	902*	562	820	-	610	762	2018	1497
600	540	127	1397	1407	940	591	978*	600	914	-	610	801	2608	1950
650	591	127	1448	1461	1016	635	1067*	636	985	-	762	837	3175	2313
700	635	127	1549	1562	1073	686	1130*	673	1060	-	914	872	3901	2858
750	686	191	1651	1664	1130	737	1194*	784	1139	-	762	1041	4581	3538
800	737	191	1778	1794	1194	781	1245*	826	1217	-	762	1083	5800	4250
850	737	191	1930	1946	1245	832	1245*	826	1217	-	762	1083	6900	5100
900	832	191	2083	2099	1314	876	1384*	894	1362	-	1067	1151	7983	5897
1100	978	229	-	-	-	1086	1651*	1067	1651	-	-	-	-	-
1400	1181	279	-	-	-	1400	1930*	1300	1964	-	-	-	-	-

■ Length (A) of a weld x flanged end valve is one half the sum of length (A) of a weld end and a flange end of the same size and rating.  
 \* Short pattern.

• Dimensions of 22 in. (550 mm) flanges are per MSS-SP-44 and 26 in. (650 mm) through 42 in. (1050 mm) flanges are per ASME B16.47 series A.

Note: Venturi opening or other reduced bore valves are available upon request.

# CAMERON FULLY WELDED BALL VALVES

FULL BORE ASME / ANSI CLASS 900 (PN 150)

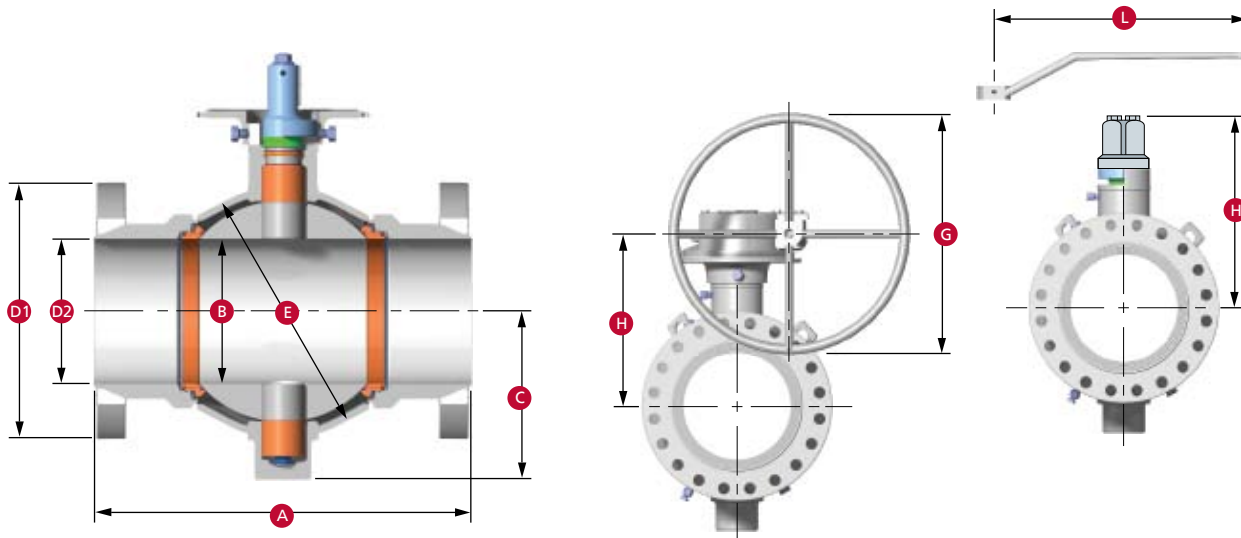

## Dimensions

SIZE in.		Ball Bore B	Stem Size	Flanged End		Weld End Length A	C.L. to Bottom C	Body Sphere E	Lever Length L	Diameter Handwheel for Gear G	C.L. to Handwheel C.L. H	Approximate Valve Weight lb.		
Nom Dia.	RF Length A			RTJ Length A	Dia. D1*							Dia. D2	Flange	Weld
2	2.06	Use 1500 Class Valves (PN 250)												
3	3.13	1.5	15.0	15.125	9.50	3.13	13.5*	4.88	7.00	36	-	7.44	140	120
4	4.06	2.0	18.0	18.125	11.50	4.06	15.0*	6.77	9.25	-	12	9.76	250	190
6	6.00	2.0	24.0	24.125	15.00	6.00	20.0*	8.39	12.50	-	18	10.86	525	410
8	8.00	2.0	29.0	29.125	18.50	8.00	23.5*	10.00	15.50	-	24	12.55	1210	590
10	10.00	3.0	33.0	33.125	21.50	10.00	25.5*	12.88	18.50	-	18	18.49	1325	1010
12	12.00	3.0	38.0	38.125	24.00	12.00	29.5*	14.50	22.36	-	24	20.14	2250	1350
14	12.75	5.0	40.5	40.875	25.25	12.75	31.5*	17.40	24.50	-	24	25.30	3250	2155
16	14.75	5.0	44.5	44.875	27.75	14.75	33.5*	19.02	27.25	-	24	26.92	4000	2450
18	16.75	5.0	48.0	48.500	31.00	16.75	36.5*	20.62	30.07	-	24	28.51	5300	3950
20	18.625	7.5	52.0	52.500	33.75	18.625	38.5*	24.22	33.88	-	24	35.23	7100	5250
24	22.50	7.5	61.0	61.750	41.00	22.50	45.0*	28.07	39.95	-	30	38.18	10500	6450
30	29.00	7.5	75.0	75.875	48.50	29.00	52.0*	32.53	49.88	-	42	42.65	17500	11500
36	34.50	9.0	90.0	91.125	57.50	34.50	59.5*	38.64	58.25	-	-	52.03	25600	17500
SIZE mm												kg		
50	52	Use 1500 Class Valves (PN 250)												
30	80	38	381	384	241	80	343*	124	178	914	-	189	64	54
100	103	51	457	460	292	103	381*	172	235	-	305	248	113	86
150	152	51	610	613	381	152	508*	213	318	-	457	276	238	186
200	203	51	737	740	410	203	597*	254	394	-	610	319	549	268
250	254	76	838	841	546	254	648*	327	470	-	457	470	601	458
300	305	76	965	968	610	305	749*	368	568	-	610	512	1021	612
350	324	127	1029	1038	641	324	800*	442	622	-	610	643	1474	977
400	375	127	1130	1140	705	375	851*	483	692	-	610	684	1814	1111
450	425	127	1219	1232	787	425	927*	524	764	-	610	724	2404	1792
500	473	191	1321	1334	857	473	978*	615	861	-	610	895	3221	2381
600	572	191	1549	1568	1041	572	1143*	713	1015	-	762	970	4763	2926
750	737	191	1905	1927	1232	737	1321*	826	1267	-	1067	1083	7938	5216
900	876	229	2286	2315	1461	876	1511*	981	1480	-	-	1322	11612	7938

■ Length (A) of a weld x flanged end valve is one half the sum of length (A) of a weld end and a flange end of the same size and rating.

\* Short pattern.

• Dimensions of 22 in. (550 mm) flanges are per MSS-SP-44 and 26 in. (650 mm) through 42 in. (1050 mm) flanges are per ASME B16.47 series A.



# CAMERON FULLY WELDED BALL VALVES

## REDUCE BORE ASME / ANSI CLASS 900 (PN 150)

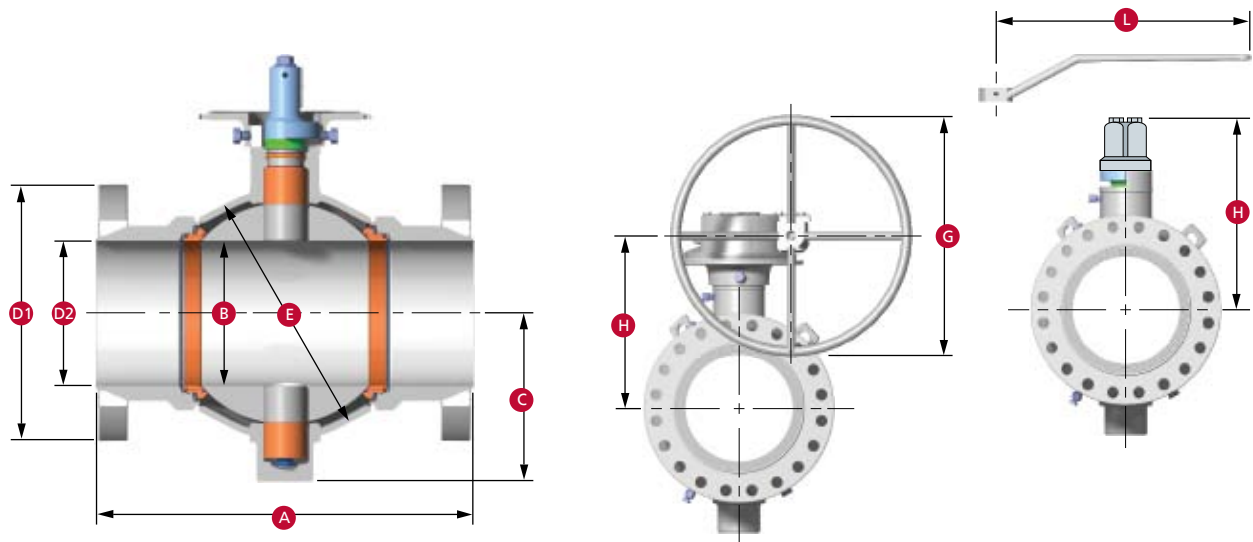

### Dimensions

SIZE in.		Stem Size	Flanged End ■		Dia. D1*	Dia. D2	Weld End ■ Length A	C.L. to Bottom C	Body Sphere E	Lever Length L	Diameter Handwheel for Gear G	C.L. to Handwheel C.L. H	Approximate Valve Weight lb.	
Nom Dia.	Ball Bore B		RF Length A	RTJ Length A									Flange	Weld
3	2.06	1.0	15.0	15.125	9.50	3.13	11.0*	3.94	5.00	24	-	6.34	120	70
4	3.13	1.5	18.0	18.125	11.50	4.06	13.5*	4.88	7.00	36	-	7.44	190	150
6	4.06	2.0	24.0	24.125	15.00	6.00	15.0*	6.77	9.25	-	12	9.76	400	260
8	6.00	2.0	29.0	29.125	18.50	8.00	20.0*	8.39	12.50	-	18	10.86	850	650
10	8.00	2.0	33.0	33.125	21.50	10.00	23.5*	10.00	15.50	-	24	12.55	1290	725
12	10.00	3.0	38.0	38.125	24.00	12.00	25.5*	12.88	18.50	-	18	18.49	1700	1110
14	12.00	3.0	40.5	40.875	25.25	12.75	29.5*	14.50	22.36	-	24	20.14	2750	1680
16	12.75	5.0	44.5	44.875	27.75	14.75	31.5*	17.40	24.50	-	24	25.30	3650	2300
SIZE mm													kg	
80	52	25	381	384	241	80	279*	100	127	610	-	161	54	32
100	80	38	457	460	292	103	343*	124	178	914	-	189	86	68
150	103	51	610	613	381	152	381*	172	235	-	305	248	181	118
200	152	51	737	740	470	203	508*	213	318	-	457	276	386	295
250	203	51	838	841	546	254	597*	254	394	-	610	319	585	329
300	254	76	965	968	610	305	648*	327	470	-	457	470	771	503
350	305	76	1029	1038	641	324	749*	368	568	-	610	512	1247	762
400	324	127	1130	1140	705	375	800*	442	622	-	610	643	1656	1043

■ Length (A) of a weld x flanged end valve is one half the sum of length (A) of a weld end and a flange end of the same size and rating.

\* Short pattern.

• Dimensions of 22 in. (550 mm) flanges are per MSS-SP-44 and 26 in. (650 mm) through 42 in. (1050 mm) flanges are per ASME B16.47 series A.

Note: Venturi opening or other reduced bore valves are available upon request.

# CAMERON FULLY WELDED BALL VALVES

FULL BORE ASME / ANSI CLASS 1500 (PN 250)

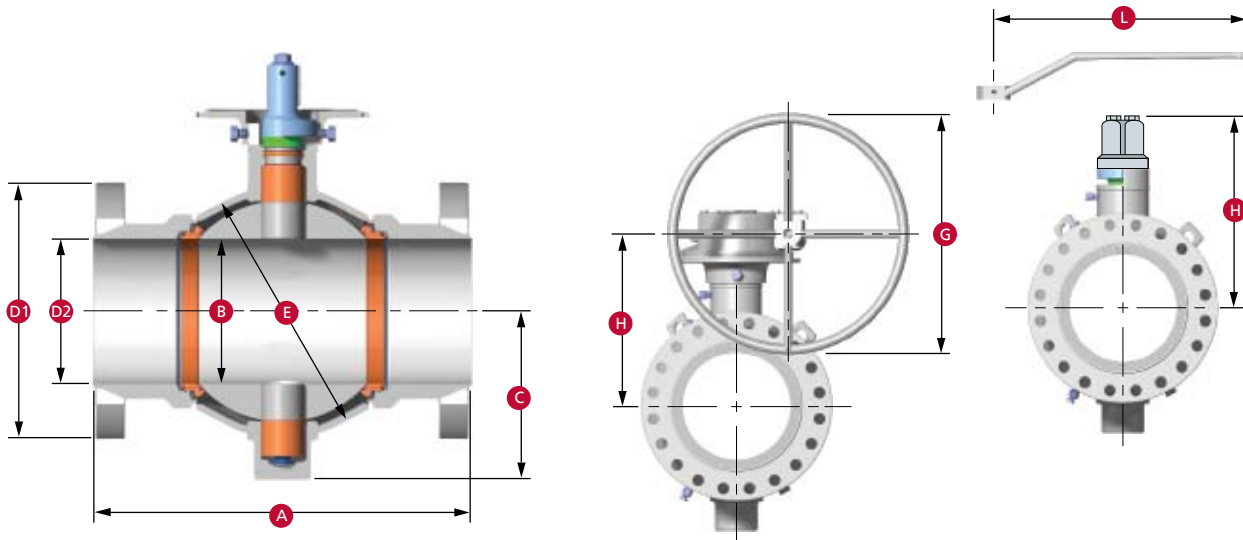

## Dimensions

SIZE in.		Flanged End ■					Weld End ■	C.L. to Bottom	Body Sphere	Lever Length	Diameter Handwheel for Gear	C.L. to Handwheel C.L.	Approximate Valve Weight lb.	
Nom Dia.	Ball Bore B	Stem Size	RF Length A	RTJ Length A	Dia. D1	Dia. D2	A	C	E	L	G	H	Flange	Weld
2	2.06	1.0	14.50	14.625	8.50	2.06	11.0*	3.94	5.00	36	-	6.34	100	45
3	3.13	1.5	18.50	18.625	10.50	3.13	13.5*	4.88	7.00	-	12	7.44	180	120
4	4.06	2.0	21.50	21.625	12.25	4.06	15.0*	6.77	9.25	-	12	9.76	300	190
6	6.00	2.0	27.75	28.000	15.50	6.00	20.0*	8.39	12.50	-	18	10.86	715	410
8	8.00	3.0	32.75	33.125	19.00	8.00	23.5*	10.95	16.38	-	18	16.89	1550	1075
10	10.00	4.0	39.00	39.375	23.00	10.00	25.5*	15.15	19.50	-	18	19.96	2000	1575
12	12.00	4.0	44.50	45.125	26.50	12.00	29.5*	17.31	23.38	-	24	21.80	3250	1825
14	12.75	5.0	49.50	50.250	29.50	12.75	31.5*	17.40	26.00	-	24	25.30	4200	2550
16	14.75	5.0	54.50	55.375	32.50	14.75	33.5*	19.02	29.25	-	30	26.92	5400	2950
18	16.75	7.5	60.50	61.375	36.00	16.75	36.5*	22.69	31.57	-	30	33.71	6350	5125
20	18.625	7.5	65.50	66.375	38.75	18.625	38.5*	24.22	34.72	-	30	35.23	9260	6025
24	22.50	7.5	76.50	77.625	46.00	22.50	45.0*	28.07	42.16	-	48	38.18	16250	9400
SIZE mm														kg
50	52	25	368	371	216	52	279*	100	127	914	-	161	45	20
80	80	38	470	473	267	80	343*	124	178	-	305	189	82	54
100	103	51	546	549	311	103	381*	172	235	-	305	248	136	86
150	152	51	705	711	394	152	508*	213	318	-	457	276	324	186
200	203	76	832	841	483	203	597*	278	416	-	457	429	703	488
250	254	102	991	1000	584	254	648*	385	495	-	457	507	907	714
300	305	102	1130	1146	673	305	749*	440	594	-	610	554	1474	828
350	324	127	1257	1276	749	324	800*	442	660	-	610	643	1905	1157
400	375	127	1384	1407	826	375	851*	483	743	-	762	684	2449	1338
450	425	191	1537	1559	914	425	927*	576	802	-	762	856	2880	2325
500	473	191	1664	1686	984	473	978*	615	882	-	762	895	4200	2733
600	572	191	1943	1972	1168	572	1143*	713	1071	-	1219	970	7371	4264

■ Length (A) of a weld x flanged end valve is one half the sum of length (A) of a weld end and a flange end of the same size and rating.

\* Short pattern.

# CAMERON FULLY WELDED BALL VALVES

## REDUCED BORE ASME / ANSI CLASS 1500 (PN 250)

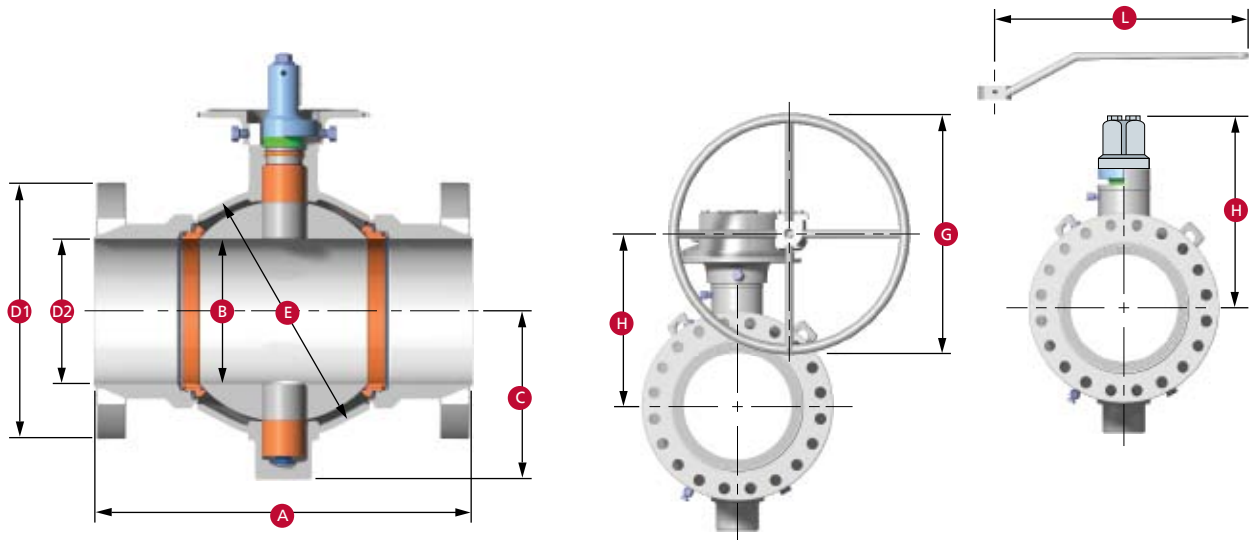

### Dimensions

SIZE in.			Flanged End ■				Weld End ■ Length	C.L. to Bottom	Body Sphere	Lever Length	Diameter Handwheel for Gear	C.L. to Handwheel C.L.	Approximate Valve Weight lb.	
Nom Dia.	Ball Bore B	Stem Size	RF Length A	RTJ Length A	Dia. D1	Dia. D2							A	C
3	2.06	1.0	18.50	18.625	10.50	3.13	11.0*	3.94	5.00	36	-	6.34	150	70
4	3.13	1.5	21.50	21.625	12.25	4.06	13.5*	4.88	7.00	-	12	7.44	240	150
6	4.06	2.0	27.75	28.000	15.50	6.00	15.0*	6.77	9.25	-	12	9.76	550	260
8	6.00	2.0	32.75	33.125	19.00	8.00	20.0*	8.39	12.50	-	18	10.86	1025	650
10	8.00	3.0	39.00	39.375	23.00	10.00	23.5*	10.95	16.38	-	18	16.89	1725	1200
12	10.00	4.0	44.50	45.125	26.50	12.00	25.5*	15.15	19.50	-	18	19.96	2810	1650
14	12.00	4.0	49.50	50.250	29.50	12.75	29.5*	17.31	23.38	-	24	21.80	3750	2100
16	12.75	5.0	54.50	55.375	32.50	14.75	31.5*	17.40	26.00	-	24	25.30	5150	2725
SIZE mm													kg	
80	52	25	470	473	267	80	279*	100	127	914	-	161	68	32
100	90	38	546	549	311	103	343*	124	178	-	305	189	109	68
150	103	51	705	711	394	152	381*	172	235	-	305	248	249	118
200	152	51	832	841	483	203	508*	213	318	-	457	276	465	295
250	203	76	991	1000	584	254	597*	278	416	-	457	429	782	544
300	254	102	1130	1146	673	305	648*	385	495	-	457	507	1275	748
350	305	102	1257	1276	749	324	749*	440	594	-	610	554	1701	953
400	324	127	1384	1407	826	375	800*	442	660	-	610	643	2336	1236

■ Length (A) of a weld x flanged end valve is one half the sum of length (A) of a weld end and a flange end of the same size and rating.  
\* Short pattern.

Note: Venturi opening or other reduced bore valves are available upon request.

# CAMERON FULLY WELDED BALL VALVES

FULL AND REDUCED BORE ASME / ANSI CLASS 2500 (PN 420)

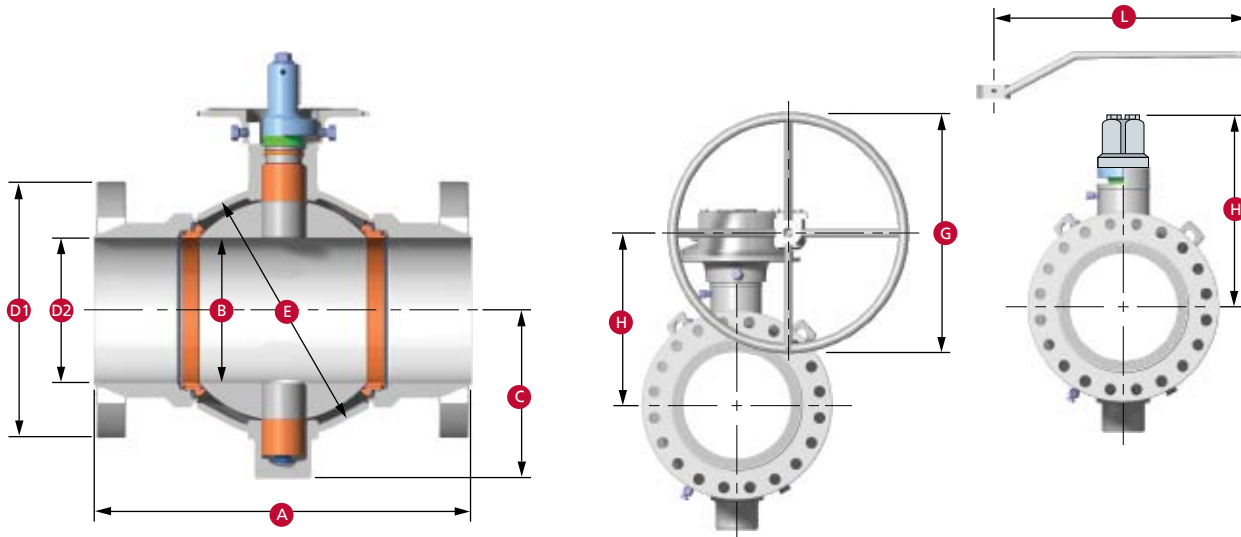

## Dimensions

SIZE in.		Flanged End ■					Weld End ■ Length	C.L. to Bottom	Body Sphere	Lever Length	Diameter Handwheel for Gear	C.L. to Handwheel C.L.	Approximate Valve Weight lb.	
Nom Dia.	Ball Bore B	Stem Size	RF Length A	RTJ Length A	Dia. D1	Dia. D2							A	C
<b>FULL OPENING</b>														
2	2.06	1.0	17.75	17.875	9.25	2.06	15*	4.53	5.43	48	-	7.25	114	94
3	3.13	1.5	22.75	23.000	12.00	3.13	18*	5.67	7.50	-	12	8.94	236	187
4	4.06	2.0	26.50	26.875	14.00	4.06	20*	7.24	9.75	-	18	11.70	471	382
6	6.00	3.0	36.00	36.500	19.00	6.00	24*	9.76	13.50	-	24	13.13	943	737
8	7.125	4.0	40.50	40.875	21.75	7.125	28*	12.84	18.11	-	24	17.88	2094	1676
10	8.875	4.0	50.00	50.875	26.50	8.875	33*	14.84	20.87	-	24	20.00	2922	2166
12	10.50	5.0	56.00	56.875	30.00	10.50	36*	16.65	24.50	-	30	24.75	4506	3258
<b>REDUCED OPENING</b>														
3	2.06	1.0	22.75	23.000	12.00	3.13	15*	4.53	5.43	48	-	7.25	156	129
4	3.13	1.5	26.50	26.875	14.00	4.06	18*	5.67	7.50	-	12	8.94	286	247
6	4.06	2.0	36.00	36.500	19.00	6.00	20*	7.24	9.75	-	18	11.70	638	513
8	6.00	3.0	40.50	40.875	21.75	7.125	24*	9.76	13.50	-	24	13.13	1297	1017
10	7.13	4.0	50.00	50.875	26.50	8.875	28*	12.84	18.11	-	24	17.88	2518	1916
12	8.875	4.0	56.00	56.875	30.00	10.50	33*	14.875	20.87	-	24	20.00	3566	2657
<b>SIZE mm</b>														<b>kg</b>
<b>FULL OPENING</b>														
50	52	25	451	454	235	52	381*	115	138	1219	-	184	52	43
80	80	38	578	584	305	80	457*	144	191	-	305	227	107	85
100	103	51	673	683	356	103	508*	184	248	-	457	297	214	173
150	152	76	914	927	483	152	610*	248	343	-	610	334	428	334
200	181	102	1029	1038	552.5	181	711*	326	460	-	610	454	950	760
250	225	102	1270	1292	673	225	838*	378	530	-	610	508	1325	983
300	267	127	1422	1445	762	267	914*	423	622	-	762	629	2044	1478
<b>REDUCED OPENING</b>														
80	42	25	578	584	305	80	381*	115	138	1219	-	184	71	59
100	80	38	673	683	356	103	457*	144	191	-	305	227	130	98
150	103	51	914	927	483	152	508*	184	248	-	457	297	289	233
200	152	76	1029	1038	553	181	610*	248	343	-	610	334	588	461
250	181	102	1270	1292	673	225	711*	326	460	-	610	454	1142	869
300	225	102	1422	1445	762	267	838*	377	530	-	610	508	1618	1205

■ Length (A) of a weld x flanged end valve is one half the sum of length (A) of a weld end and a flange end of the same size and rating.

\* Short pattern.

Note: Venturi opening or other reduced bore valves are available upon request.

# CAMERON FULLY WELDED BALL VALVES

FULL BORE API FLANGED 2000, 3000 & 5000 psi WP

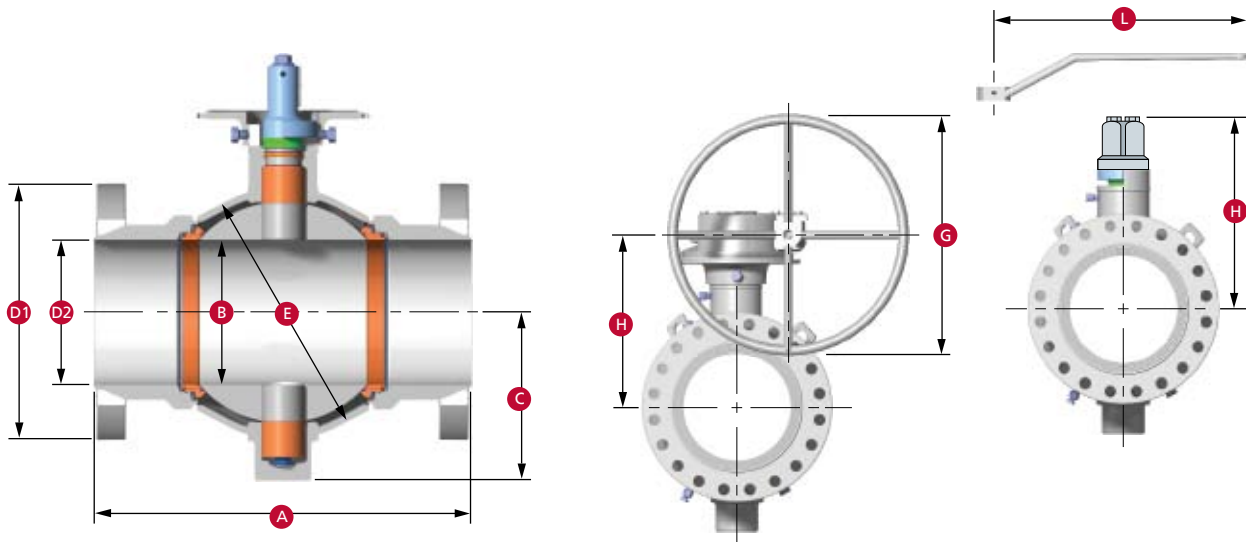

## Dimensions

SIZE in.		Ball Bore B	Stem Size	Flanged End RTJ			C.L. to Bottom C	Body Sphere E	Lever Length L	Diameter Handwheel for Gear G	Data for Valve with Operator Normally Furnished	
Nom Dia.	Length A			Length D1	Dia. D2	H					Approx. Weight lb.	
<b>2000 psi W.P. 4000 psi TEST</b>												
2	2.06	1.0	11.625	6.50	2.06	3.94	5.00	36	-	6.34	44	
3	3.13	1.0	14.124	8.25	3.13	5.12	6.75	36	-	7.44	85	
4	4.06	1.5	17.125	10.75	4.06	5.94	8.50	36	-	8.43	165	
7	6.00	2.0	22.125	14.00	6.00	7.91	11.50	-	24	10.29	445	
<b>3000 psi W.P. 6000 psi TEST</b>												
2	2.06	1.0	14.625	8.50	2.06	3.94	5.00	36	-	6.34	90	
3	3.13	1.5	15.125	9.50	3.13	4.88	7.00	36	-	7.44	130	
4	4.06	2.0	18.125	11.50	4.06	6.77	9.25	36	-	9.76	255	
7	6.00	2.0	24.125	15.00	6.00	8.39	12.50	-	30	10.92	675	
<b>5000 psi W.P. 10000 psi TEST</b>												
2	2.06	2.0	14.625	8.50	2.06	3.94	5.00	36	-	6.34	95	
3	3.13	1.5	18.625	10.50	3.13	4.88	7.00	36	-	7.44	189	
4	4.06	2.0	21.625	12.25	4.06	6.77	9.25	-	24	9.30	361	
7	6.00	3.0	28.000	15.50	6.00	8.39	13.50	-	24	13.13	805	
<b>SIZE mm</b>												<b>kg</b>
<b>140.6 kg/cm<sup>2</sup> W.P. 281.2 kg/cm<sup>2</sup> TEST</b>												
50	52.3	25.4	295	165	52	100	127	914	-	161	20	
80	79.5	25.4	359	210	80	130	171	914	-	189	39	
100	103.1	38.1	435	274	103	151	216	914	-	214	75	
180	152.4	50.8	562	356	152	201	292	-	610	261	202	
<b>210.9 kg/cm<sup>2</sup> W.P. 421.8 kg/cm<sup>2</sup> TEST</b>												
50	52.3	25.4	371	216	52	100	127	914	-	161	41	
80	79.5	38.1	384	241	80	124	178	914	-	189	59	
100	103.1	50.8	460	292	103	172	235	914	-	248	116	
180	152.4	50.8	613	381	152	213	318	-	762	277	306	
<b>351.5 kg/cm<sup>2</sup> W.P. 703.0 kg/cm<sup>2</sup> TEST</b>												
50	52.3	25.4	371	216	52	100	127	914	-	161	43	
80	79.5	38.1	473	267	80	124	178	914	-	189	86	
100	103.1	50.8	549	311	103	172	235	914	-	236	164	
180	152.4	76.2	711	394	152	213	343	-	610	334	365	

# CAMERON FULLY WELDED BALL VALVES

REDUCED BORE API FLANGED 2000, 3000 & 5000 psi WP

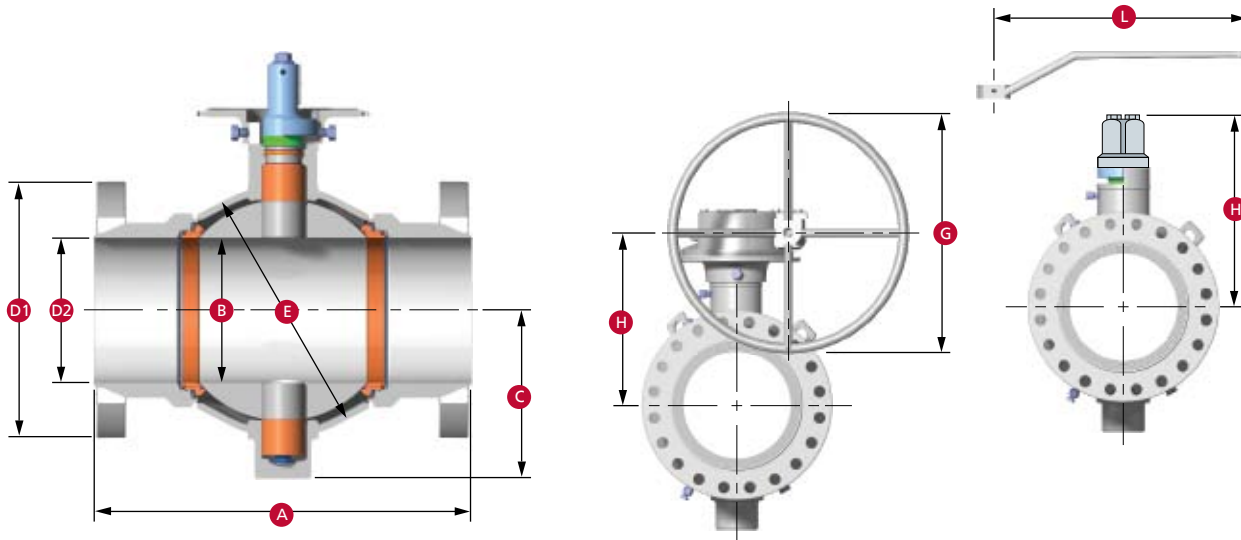

## Dimensions

SIZE in.		Flanged End RTJ			C.L. to Bottom C	Body Sphere E	Lever Length L	Diameter Handwheel for Gear G	Data for Valve with Operator Normally Furnished		
Nom Dia.	Ball Bore B	Stem Size	Length A	Length D1					Dia. D2	H	Approx. Weight lb.
<b>2000 psi W.P. 4000 psi TEST</b>											
3.13	2.06	1.0	14.125	8.25	3.13	3.94	5.00	36	-	6.34	80
4.06	3.13	1.0	17.125	10.75	4.06	5.12	6.75	36	-	7.44	140
7.06	4.06	1.5	22.125	14.00	6.00	5.94	8.50	36	-	8.43	230
<b>3000 psi W.P. 6000 psi TEST</b>											
3.13	2.06	1.0	15.125	9.50	3.13	3.94	5.00	36	-	6.34	105
4.06	3.13	1.5	18.125	11.50	4.06	4.88	7.00	36	-	7.44	197
7.06	4.06	2.0	24.125	15.00	6.00	6.77	9.25	36	-	9.76	345
<b>5000 psi W.P. 10000 psi TEST</b>											
3.13	2.06	1.0	18.625	10.50	3.13	3.94	5.00	36	-	6.34	130
4.06	3.13	1.5	21.625	12.25	4.06	4.88	7.00	36	-	7.44	230
7.06	4.06	2.0	28.000	15.50	6.00	6.77	9.25	-	24	9.30	490
<b>SIZE mm</b>											<b>kg</b>
<b>140.6 kg/cm<sup>2</sup> W.P. 281.2 kg/cm<sup>2</sup> TEST</b>											
79.5	52.3	25.4	359	210	80	100	127	914	-	161	36
103.1	79.5	25.4	435	273	103	130	171	914	-	189	64
179.3	103.1	38.1	562	356	152	151	216	914	-	214	104
<b>210.9 kg/cm<sup>2</sup> W.P. 421.8 kg/cm<sup>2</sup> TEST</b>											
79.5	52.3	25.4	384	241	80	100	127	914	-	161	48
103.1	79.5	38.1	460	292	103	124	178	914	-	189	89
179.4	103.1	50.8	613	381	152	172	235	914	-	248	156
<b>351.5 kg/cm<sup>2</sup> W.P. 703.0 kg/cm<sup>2</sup> TEST</b>											
79.5	52.3	25.4	473	267	80	100	127	914	-	161	59
103.1	79.5	38.1	549	311	103	124	178	914	-	189	104
179.3	103.1	50.8	711	394	152	172	235	-	610	236	222

# CAMERON FULLY WELDED BALL VALVES

## DIMENSIONAL DATA

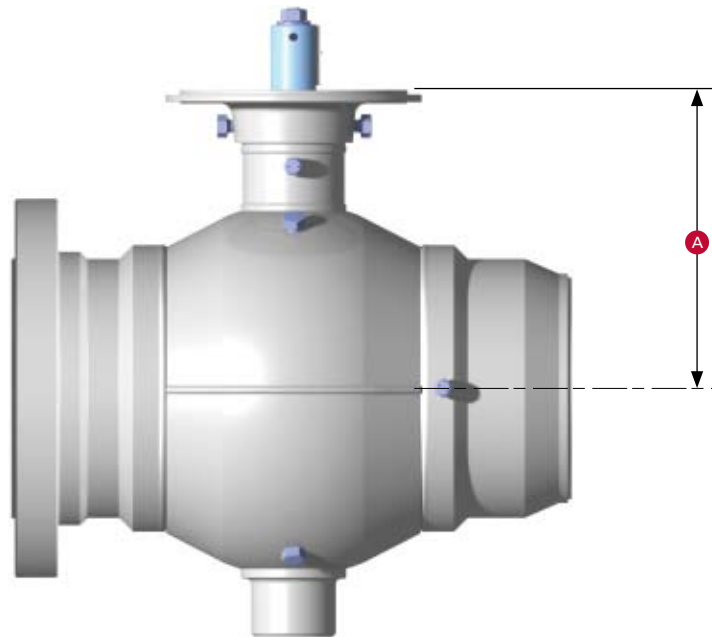

Dimensions CenterLine to Mounting Flanged

Bore Size		Dimension A						
		ASME/ANSI Pressure Class						
in.	(mm)	150 (PN 20)	300 (PN 50)	400 (PN 64)	600 (PN 100)	900 (PN 150)	1500 (PN 250)	2500 (PN 420)
2	(50)	4.06 (103)	4.06 (103)	4.06 (103)	4.06 (103)	4.06 (103)	4.06 (103)	4.68 (119)
3	(80)	5.08 (129)	5.08 (129)	5.08 (129)	5.08 (129)	4.76 (121)	4.76 (121)	5.71 (145)
4	(100)	5.79 (147)	5.79 (147)	5.79 (147)	5.79 (147)	6.61 (168)	6.61 (168)	6.89 (175)
6	(150)	7.64 (194)	7.64 (194)	7.64 (194)	7.64 (194)	8.23 (209)	8.23 (209)	12.52 (318)
8	(200)	9.92 (252)	9.92 (252)	9.92 (252)	9.92 (252)	9.92 (252)	13.45 (342)	15.39 (391)
10	(250)	11.91 (303)	11.91 (303)	11.91 (303)	11.91 (303)	15.05 (382)	15.96 (405)	18.07 (459)
12	(300)	16.70 (424)	16.70 (424)	16.70 (424)	16.70 (424)	16.70 (424)	17.80 (452)	19.61 (498)
14	(350)	17.72 (450)	17.72 (450)	17.72 (450)	17.72 (450)	20.55 (522)	20.55 (522)	-
16	(400)	19.08 (485)	19.08 (485)	20.78 (528)	20.78 (528)	22.17 (563)	22.17 (563)	-
18	(450)	22.19 (564)	22.19 (564)	22.19 (564)	22.19 (564)	23.76 (604)	27.71 (704)	-
20	(500)	23.75 (603)	23.75 (603)	25.25 (641)	25.25 (641)	29.23 (742)	29.23 (742)	-
22	(550)	25.22 (641)	25.22 (641)	26.78 (680)	26.78 (680)	-	-	-
24	(600)	26.63 (676)	26.63 (676)	28.20 (716)	28.20 (716)	32.18 (817)	32.18 (817)	-
26	(650)	29.59 (752)	29.59 (752)	29.59 (752)	29.59 (752)	-	-	-
28	(700)	30.97 (787)	30.97 (787)	30.97 (787)	34.99 (889)	-	-	-
30	(750)	32.62 (829)	32.62 (829)	32.62 (829)	36.65 (931)	36.65 (931)	-	-
34	(850)	35.26 (896)	35.26 (896)	39.31 (998)	39.31 (998)	-	-	-
36	(900)	36.85 (936)	40.92 (1039)	40.92 (1039)	40.92 (1039)	44.65 (1134)	-	-
40	(1000)	44.25 (1124)	44.25 (1124)	44.25 (1124)	48.05 (1220)	-	-	-
42	(1050)	45.89 (1166)	45.89 (1166)	45.89 (1166)	49.69 (1262)	-	-	-
48	(1200)	50.04 (1271)	50.04 (1271)	54.02 (1372)	56.50 (1435)	-	-	-

The dimensions on this page, combined with the top works dimensions on the following two pages, provide the information required for determining the overall dimensions of a Cameron Fully Welded Ball Valve when an actuator is installed.

For additional dimensional information on Cameron Fully Welded Ball Valves, contact your Cameron's Valves & Measurement group representative.



# CAMERON FULLY WELDED BALL VALVES

## TOP WORKS DIMENSIONS

### Square Nut and Adapter Flange (BX-1220)

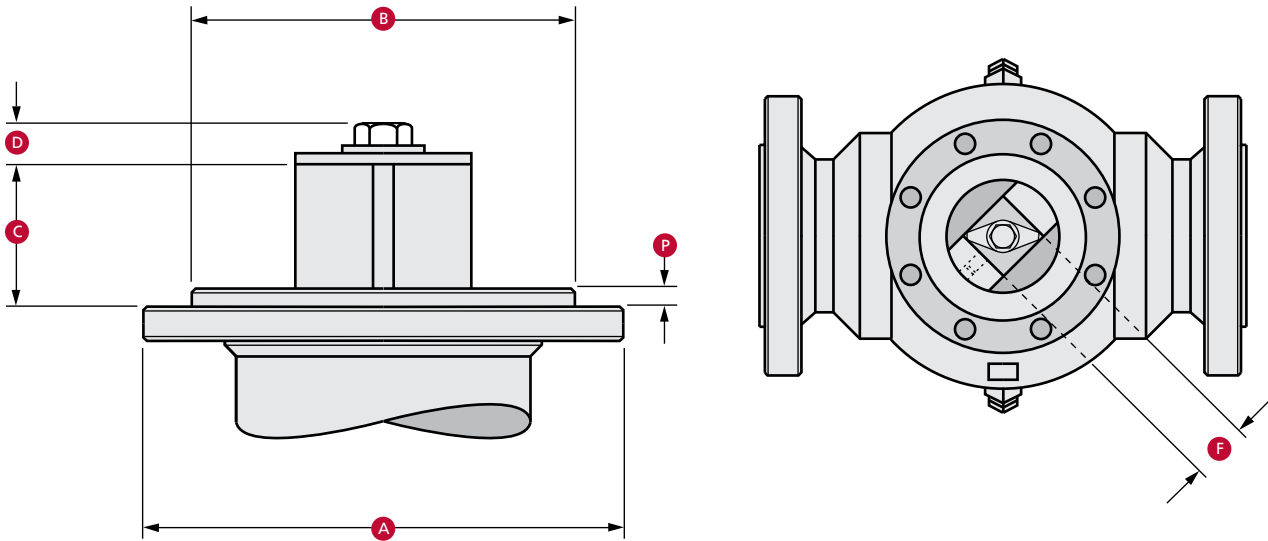

### Mounting Dimensions

DASH NUMBER	-1	-2	-3
<b>Valve Stem Size in.</b>	<b>1.00</b>	<b>1.50</b>	<b>2.00</b>
A Flange Dia.	6.50	6.50	8.75
B Boss Dia.	4.747	4.747	6.997
C Height of Nut	1.94	2.12	2.62
D Bolt Size	0.44	0.54	0.66
F Width of Nut	1.50	2.00	2.50
H Number of Holes	8	8	16
J Dia. Bolt Circle	5.75	5.75	8.00
P Boss Height	0.328	0.328	0.328
Flange Bolt Size	3/8-16 NC-2	3/8-16 NC-2	3/8-16 NC-2
Bolt Torque (ft. lb.)	30	30	30
DASH NUMBER	-1	-2	-3
<b>Valve Stem Size mm</b>	<b>25.40</b>	<b>38.10</b>	<b>50.80</b>
A Flange Dia.	165.10	165.10	222.25
B Boss Dia.	120.57	120.57	177.72
C Height of Nut	49.28	53.85	66.55
D Bolt Size	11.18	13.72	16.76
F Width of Nut	38.10	50.8	63.50
H Number of Holes	8	8	16
J Dia. Bolt Circle	146.05	146.05	203.20
P Boss Height	8.33	8.33	8.33
Flange Bolt Size	3/8-16 NC-2	3/8-16 NC-2	3/8-16 NC-2
Bolt Torque (Nm)	40.68	40.68	40.68

Notes: -1 and -2 bolt holes straddle centerline.  
 -3 bolt holes are on centerline.

# CAMERON FULLY WELDED BALL VALVES

## TOP WORKS DIMENSIONS

### Keyed Shaft and Adapter Flange (BX-1221)

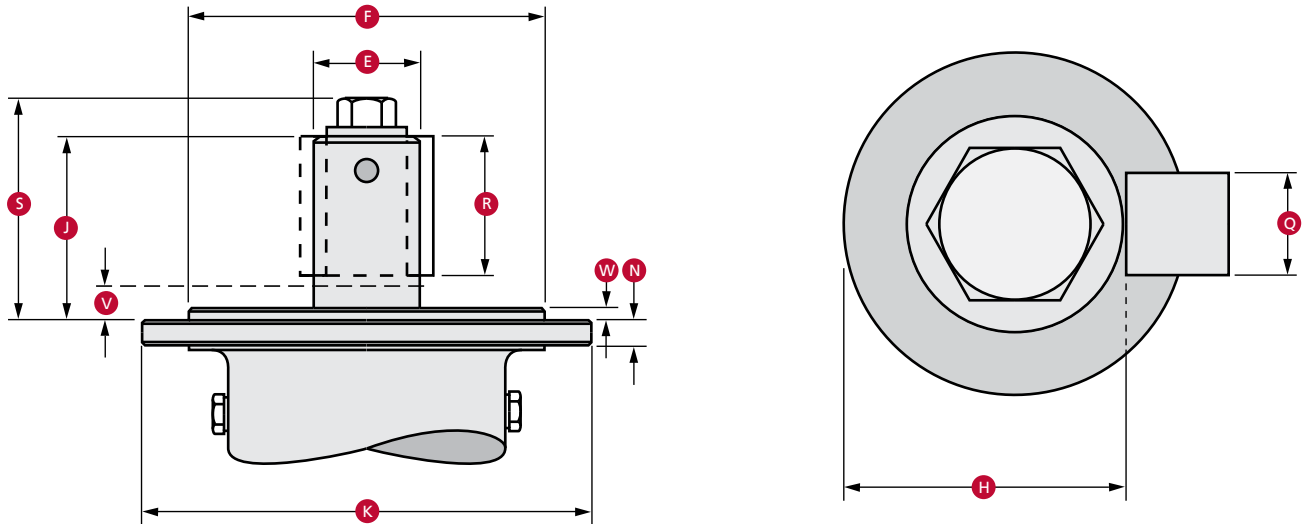

### Mounting Dimensions

DASH NUMBER	-4	-5	-6	-7	-8	-9	-10	-11
Valve Stem Size in.	3.00	4.00	5.00	7.50	9.00	11.00	13.00	15.00
A Number of Holes	16	16	24	24	24	28	28	32
C Dia. Bolt Circle	10.375	17.25	18.375	24.00	31.00	27.50	27.50	36.00
E Max Shaft Dia.	2.745	3.245	4.495	5.495	6.245	8.995	8.995	-
F Boss Dia.	9.122	16.246	17.121	21.746	28.308	25.496	25.496	33.496
H Key Seat	2.402	2.831	3.786	4.803	5.409	7.887	6.774	-
J Height of Nut	4.75	5.310	6.25	8.50	9.13	13.31	13.31	19.25
K Flange Dia.	11.50	18.25	19.380	25.75	32.75	30.00	30.00	39.00
N Flange Thickness	0.63	0.63	0.63	1.00	1.00	1.25	1.25	1.50
Q Key Width	0.625	0.75	1.25	1.25	1.50	2.00	2.00	2.25
R Key Length	3.75	4.310	5.250	7.50	8.13	12.00	12.00	17.50
S Overall Height	6.120	7.00	8.120	11.00	11.75	16.12	15.84	21.50
V Adapter Flange Thickness (Max.)	1.00	1.00	1.00	1.00	1.00	1.25	1.25	1.50
W Boss Height	0.328	0.328	0.328	0.328	0.328	0.328	0.328	0.328
Flange Bolt Size	1/2-13 NC-2	1/2-13 NC-2	1/2-13 NC-2	7/8-9 NC-2	7/8-9 NC-2	1 1/4-8 NC-2	1 1/4-8 NC-2	1 1/4-8 NC-2
Bolt Torque (ft. lb.)	60	60	63	330	330	1000	1000	1600
DASH NUMBER	-4	-5	-6	-7	-8	-9	-10	-11
Valve Stem Size mm	76.20	101.60	127.00	190.50	228.60	279.40	330.20	381.00
A Number of Holes	16	16	24	24	24	28	28	32
C Dia. Bolt Circle	263.53	438.15	466.73	609.60	787.40	698.50	698.50	914.40
E Max Shaft Dia.	69.73	82.43	114.18	139.58	158.63	228.48	228.48	-
F Boss Dia.	231.69	412.64	434.87	552.34	719.02	647.59	647.59	850.79
H Key Seat	61.01	71.91	96.16	122.00	137.38	200.32	172.05	-
J Height of Nut	120.65	134.88	158.75	215.90	231.91	338.03	338.03	488.95
K Flange Dia.	292.10	463.55	492.26	654.05	831.85	762.00	763.00	990.60
N Flange Thickness	16.00	16.00	16.00	25.40	25.40	31.75	31.75	38.10
Q Key Width	15.88	19.05	31.75	31.75	38.10	50.80	50.80	57.15
R Key Length	95.25	109.48	133.35	190.50	206.51	304.80	304.80	444.50
S Overall Height	155.45	177.80	206.25	279.40	298.45	409.45	402.34	546.10
V Adapter Flange Thickness (Max.)	25.40	25.40	25.40	25.40	25.40	31.75	31.75	38.10
W Boss Height	8.33	8.33	8.33	8.33	8.33	8.33	8.33	8.33
Flange Bolt Size	1/2-13 NC-2	1/2-13 NC-2	1/2-13 NC-2	7/8-9 NC-2	7/8-9 NC-2	1 1/4-8 NC-2	1 1/4-8 NC-2	1 1/4-8 NC-2
Bolt Torque (Nm)	81	81	85	447	447	1356	1356	2169

Notes: -7 through -11 bolt holes straddle centerline.  
 -4 through -6 holes are on centerline.

# CAMERON FULLY WELDED BALL VALVES

## TOP WORKS DIMENSIONS - MANUAL GEAR DIMENSIONS

### DYNATORQUE™

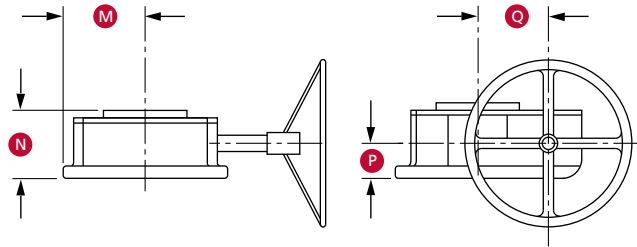

Stem Size		Model	Effective Ratio	Number of Turns Per 90°	M	N	P	Q	Weight	
in.	(mm)								lb.	(kg)
1.0	(25.4)	DT21	22.5:1	15	3.56 (90)	3.54 (90)	1.63 (41)	3.63 (92)	36	(16)
1.5	(38.1)	DT21	22.5:1	15	3.56 (90)	3.54 (90)	1.63 (41)	3.63 (92)	36	(16)
2.0	(50.8)	DT40	27.6:1	19.75	5.68 (144)	4.83 (123)	2.25 (57)	4.63 (118)	75	(34)
3.0	(76.2)	DT54	91.2:1	79.5	5.66 (144)	6.83 (173)	4.94 (125)	4.30 (109)	108	(49)

### CAMERON

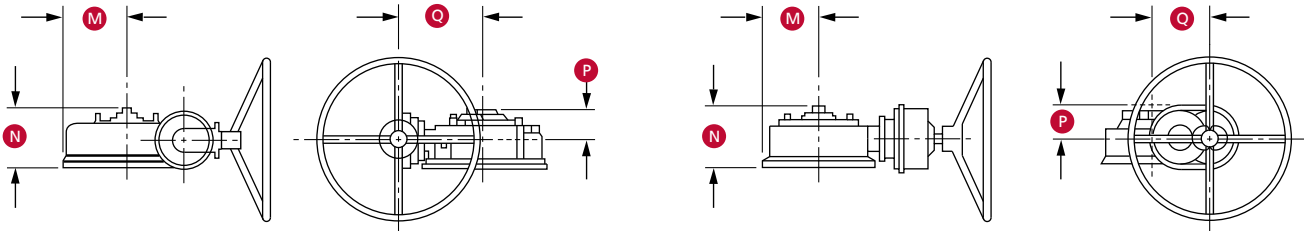

Cameron Gear Box  
Stem Size: 3 in. & 4 in. (80 mm & 100 mm)

Cameron Gear Box  
Stem Size: 5 in., 7.5 in. & 9 in. (125 mm, 190 mm & 230 mm)

Stem Size		Model	Effective Ratio	Number of Turns Per 90°	M	N	P	Q	Weight	
in.	(mm)								lb.	(kg)
3.0	(76.2)	WG1/B6	55:1	60	5.75 (146)	7.56 (192)	4.11 (104)	12.64 (321)	127	(58)
4.0	(101.6)	WG1/B6	110:1	112.5	9.13 (232)	8.69 (221)	4.69 (119)	12.64 (321)	211	(96)
5.0	(127.0)	WG1/S12	153:1	190	9.69 (246)	10.25 (260)	5.50 (140)	9.50 (241)	364	(165)
7.5	(190.5)	WG1/S12	297:1	297	12.88 (327)	12.63 (321)	6.63 (168)	14.00 (356)	581	(264)
9.0	(228.6)	WG1/S12	432:1	428	16.37 (416)	14.77 (375)	7.39 (188)	19.50 (495)	793	(360)

## CAMSERV™ AFTERMARKET SERVICES



Cameron's Aftermarket Services' goal is to help our customers lower the total cost of valve ownership. To that end we offer a full range of services from over twenty-five Service Centers worldwide and can provide experienced personnel trained to meet the specific service requirements of each valve type.

### Aftermarket Services

- Supplies replacement valves and parts:
  - Maintains a full inventory of new and reconditioned valves for immediate delivery
  - Provides factory warranty support for all Cameron OEM brands as well as service for most other valves
- Field Service & Technical Support
  - Field service technicians on call 24 hours a day 7 days a week to handle service issues wherever they arise
  - Provides equipment installation, field repairs, as well as track and perform scheduled maintenance
- Customer Property Repair
  - The Customer Property Repair program allows Cameron valve customers to store assets at our service centers throughout the world
  - Valves tracked in electronic database accessible through the Internet
- Remanufactured Products
  - Offers a broad range of API-compliant reconditioned equipment with fast delivery
- Total Valve Management
  - Supply and service automation and control packages
  - Assist with valve installation, commissioning and start-up



## TRADEMARK INFORMATION

CAMERON is a registered trademark which is owned by Cameron.

This document contains references to registered trademarks or product designations, which are not owned by Cameron.

Trademark	Owner
CELCON	Hoechst Celanese Corporation
DELRIN	E.I. DuPont De Nemours & Company
FLUOREL	Minnesota Mining and Manufacturing Company
HASTELLOYS	Haynes International, Inc.
HYCAR	Hydrocarbon Chemical and Rubber Company
HYDRIN	Zeon Chemicals USA, Inc.
HYPALON	E.I. DuPont De Nemours & Company
INCONEL	INCO Nickel Sales, Inc.
MONEL	INCO Alloys International, Inc.
NORDEL	E.I. DuPont De Nemours & Company
STELLITE	Stoody Deloro Stellite, Inc.
TEFLON	E.I. DuPont De Nemours & Company
VITON	E.I. DuPont De Nemours & Company



**Valves & Measurement**

**3250 Briarpark Drive, Suite 300  
Houston, TX 77042  
USA Toll 800 323 9160**

For the most current contact and location information go to: [www.c-a-m.com](http://www.c-a-m.com)

Cameron strives for continuous improvement in all aspects of our business. Cameron reserves the right to modify designs and specifications without notice or obligation. Nothing contained in this brochure is intended to extend any type of warranty, expressed or implied.